

**Ersatzteillisten
Listes des pièces de rechange
Liste dei pezzi di ricambio
Spare parts lists**

**STANDKOCHKESSEL
MARMITES FIXES
PENTOLE FISSE
STATIONARY BOILING PANS**

**THERMETIC
BEN-E / S / H
PEN-E / S / H**

D, F, I, GB

76.9274 (10)

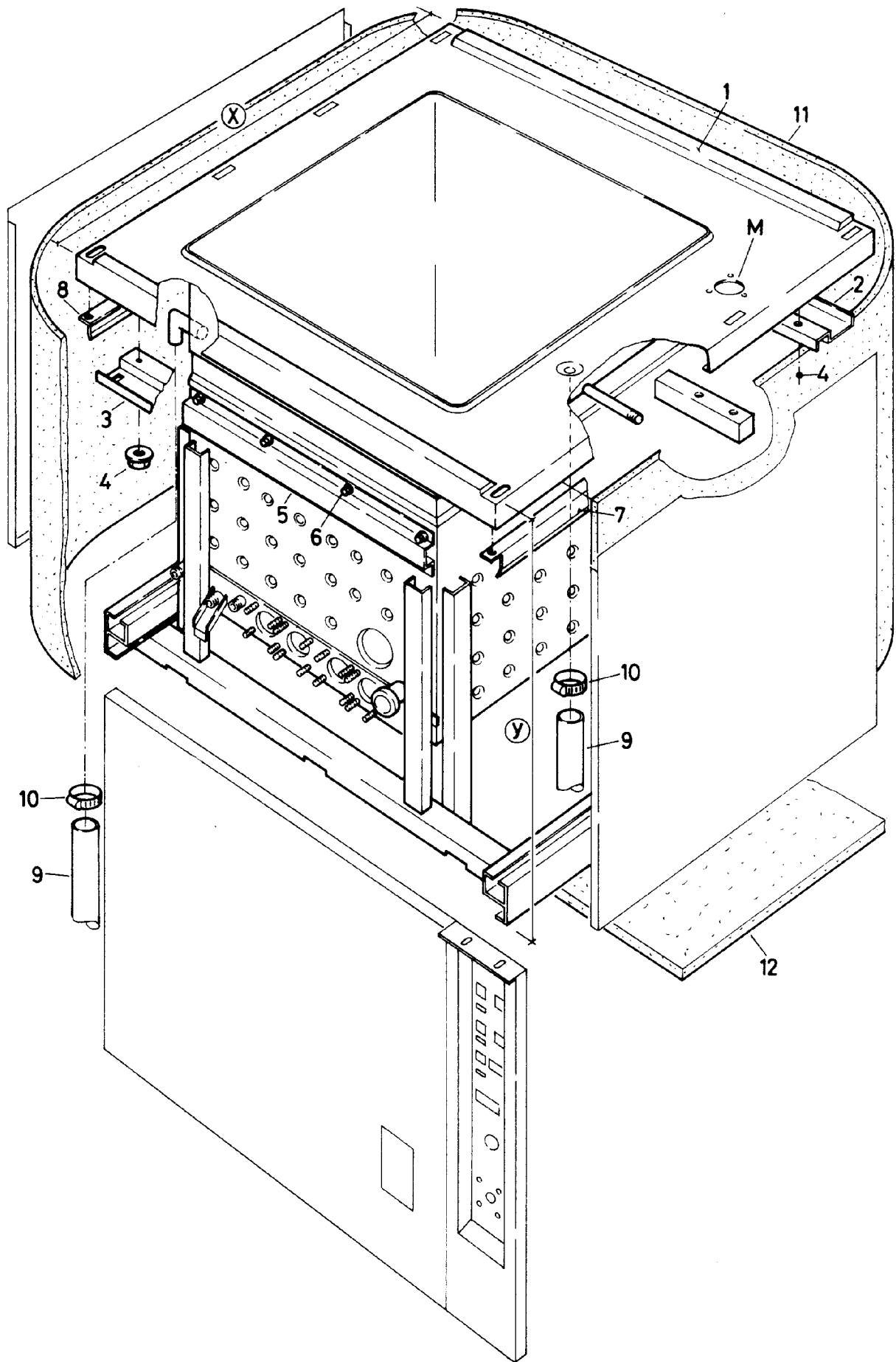

Doc. No.	Index	Issue	DE	FR	IT	GB	Seite/ Page/ Pagina/ Page								
76.9274.01		12/97	Baugruppe	Unité	Unità	Unit	1								
BEN-E			Kessel	Marmite	Marmitta	Kettle									

Pos.	Product No.	Service No.	Bezeichnung	Désignation	Designazione	Designation	Type	x	y	M	80	150	200	300	400	Introduc-tion
1	76.5011.01		Kessel	marmite	marmitta	kettle		800	700		1					12/97
	76.5011.02		Kessel	marmite	marmitta	kettle		800	700			1				12/97
	76.5011.03		Kessel	marmite	marmitta	kettle		800	700				1			12/97
	76.5011.04		Kessel	marmite	marmitta	kettle		800	700					1		12/97
	76.5011.05		Kessel	marmite	marmitta	kettle		800	700						1	12/97
	76.5011.06		Kessel	marmite	marmitta	kettle		900	700		1					12/97
	76.5011.07		Kessel	marmite	marmitta	kettle		900	700			1				12/97
	76.5011.08		Kessel	marmite	marmitta	kettle		900	700				1			12/97
	76.5011.09		Kessel	marmite	marmitta	kettle		900	700					1		12/97
	76.5011.10		Kessel	marmite	marmitta	kettle		900	700						1	12/97
	76.5011.11		Kessel	marmite	marmitta	kettle		800	700	M	1					12/97
	76.5011.12		Kessel	marmite	marmitta	kettle		800	700	M		1				12/97
	76.5011.13		Kessel	marmite	marmitta	kettle		800	700	M			1			12/97
	76.5011.14		Kessel	marmite	marmitta	kettle		800	700	M				1		12/97
	76.5011.15		Kessel	marmite	marmitta	kettle		800	700	M					1	12/97
	76.5011.16		Kessel	marmite	marmitta	kettle		900	700	M	1					12/97
	76.5011.17		Kessel	marmite	marmitta	kettle		900	700	M		1				12/97
	76.5011.18		Kessel	marmite	marmitta	kettle		900	700	M			1			12/97
	76.5011.19		Kessel	marmite	marmitta	kettle		900	700	M				1		12/97
	76.5011.20		Kessel	marmite	marmitta	kettle		900	700	M					1	12/97
	76.5011.21		Kessel	marmite	marmitta	kettle		800	800		1					12/97
	76.5011.22		Kessel	marmite	marmitta	kettle		800	800			1				12/97
	76.5011.23		Kessel	marmite	marmitta	kettle		800	800				1			12/97
	76.5011.24		Kessel	marmite	marmitta	kettle		800	800					1		12/97
	76.5011.25		Kessel	marmite	marmitta	kettle		800	800						1	12/97
	76.5011.26		Kessel	marmite	marmitta	kettle		900	800		1					12/97
	76.5011.27		Kessel	marmite	marmitta	kettle		900	800			1				12/97
	76.5011.28		Kessel	marmite	marmitta	kettle		900	800				1			12/97
	76.5011.29		Kessel	marmite	marmitta	kettle		900	800					1		12/97
	76.5011.30		Kessel	marmite	marmitta	kettle		900	800						1	12/97
	76.5011.31		Kessel	marmite	marmitta	kettle		800	800	M	1					12/97
	76.5011.32		Kessel	marmite	marmitta	kettle		800	800	M		1				12/97

Doc. No.	Index	Issue	DE	FR	IT	GB	Seite/ Page/ Pagina/ Page						
76.9274.01		12/97	Baugruppe	Unité	Unità	Unit	2						
BEN-E			Kessel	Marmite	Marmitta	Kettle							

Pos.	Product No.	Service No.	Bezeichnung	Désignation	Designatione	Designation	Type	x	y	M	80	150	200	300	400	Introduc-tion
1	76.5011.33		Kessel	marmite	marmitta	kettle		800	800	M			1			12/97
	76.5011.34		Kessel	marmite	marmitta	kettle		800	800	M				1		12/97
	76.5011.35		Kessel	marmite	marmitta	kettle		800	800	M					1	12/97
	76.5011.36		Kessel	marmite	marmitta	kettle		900	800	M	1					12/97
	76.5011.37		Kessel	marmite	marmitta	kettle		900	800	M		1				12/97
	76.5011.38		Kessel	marmite	marmitta	kettle		900	800	M			1			12/97
	76.5011.39		Kessel	marmite	marmitta	kettle		900	800	M				1		12/97
	76.5011.40		Kessel	marmite	marmitta	kettle		900	800	M					1	12/97

Doc. No.	Index	Issue	DE	FR	IT	GB	Seite/ Page/ Pagina/ Page					
76.9274.01		12/97	Baugruppe	Unité	Unità	Unit	3					
BEN-S			Kessel	Marmite	Marmitta	Kettle						

Pos.	Product No.	Service No.	Bezeichnung	Désignation	Designazione	Designation	Type	x	y	M	80	150	200	300	400	Introduc-tion
1	76.5318.01		Kessel	marmite	marmitta	kettle		800	700		1					12/97
	76.5318.02		Kessel	marmite	marmitta	kettle		800	700			1				12/97
	76.5318.03		Kessel	marmite	marmitta	kettle		800	700				1			12/97
	76.5318.04		Kessel	marmite	marmitta	kettle		800	700					1		12/97
	76.5318.05		Kessel	marmite	marmitta	kettle		800	700						1	12/97
	76.5318.06		Kessel	marmite	marmitta	kettle		900	700		1					12/97
	76.5318.07		Kessel	marmite	marmitta	kettle		900	700			1				12/97
	76.5318.08		Kessel	marmite	marmitta	kettle		900	700				1			12/97
	76.5318.09		Kessel	marmite	marmitta	kettle		900	700					1		12/97
	76.5318.10		Kessel	marmite	marmitta	kettle		900	700						1	12/97
	76.5318.11		Kessel	marmite	marmitta	kettle		800	700	M	1					12/97
	76.5318.12		Kessel	marmite	marmitta	kettle		800	700	M		1				12/97
	76.5318.13		Kessel	marmite	marmitta	kettle		800	700	M			1			12/97
	76.5318.14		Kessel	marmite	marmitta	kettle		800	700	M				1		12/97
	76.5318.15		Kessel	marmite	marmitta	kettle		800	700	M					1	12/97
	76.5318.16		Kessel	marmite	marmitta	kettle		900	700	M	1					12/97
	76.5318.17		Kessel	marmite	marmitta	kettle		900	700	M		1				12/97
	76.5318.18		Kessel	marmite	marmitta	kettle		900	700	M			1			12/97
	76.5318.19		Kessel	marmite	marmitta	kettle		900	700	M				1		12/97
	76.5318.20		Kessel	marmite	marmitta	kettle		900	700	M					1	12/97
	76.5318.21		Kessel	marmite	marmitta	kettle		800	800		1					12/97
	76.5318.22		Kessel	marmite	marmitta	kettle		800	800			1				12/97
	76.5318.23		Kessel	marmite	marmitta	kettle		800	800				1			12/97
	76.5318.24		Kessel	marmite	marmitta	kettle		800	800					1		12/97
	76.5318.25		Kessel	marmite	marmitta	kettle		800	800						1	12/97
	76.5318.26		Kessel	marmite	marmitta	kettle		900	800		1					12/97
	76.5318.27		Kessel	marmite	marmitta	kettle		900	800			1				12/97
	76.5318.28		Kessel	marmite	marmitta	kettle		900	800				1			12/97
	76.5318.29		Kessel	marmite	marmitta	kettle		900	800					1		12/97
	76.5318.30		Kessel	marmite	marmitta	kettle		900	800						1	12/97
	76.5318.31		Kessel	marmite	marmitta	kettle		800	800	M	1					12/97
	76.5318.32		Kessel	marmite	marmitta	kettle		800	800	M		1				12/97

Doc. No.	Index	Issue	DE	FR	IT	GB	Seite/ Page/ Pagina/ Page						
76.9274.01		12/97	Baugruppe	Unité	Unità	Unit	4						
BEN-S			Kessel	Marmite	Marmitta	Kettle							

Pos.	Product No.	Service No.	Bezeichnung	Désignation	Designatione	Designation	Type	x	y	M	80	150	200	300	400	Introduc-tion
1	76.5318.33		Kessel	marmite	marmitta	kettle		800	800	M			1			12/97
	76.5318.34		Kessel	marmite	marmitta	kettle		800	800	M				1		12/97
	76.5318.35		Kessel	marmite	marmitta	kettle		800	800	M					1	12/97
	76.5318.36		Kessel	marmite	marmitta	kettle		900	800	M	1					12/97
	76.5318.37		Kessel	marmite	marmitta	kettle		900	800	M		1				12/97
	76.5318.38		Kessel	marmite	marmitta	kettle		900	800	M			1			12/97
	76.5318.39		Kessel	marmite	marmitta	kettle		900	800	M				1		12/97
	76.5318.40		Kessel	marmite	marmitta	kettle		900	800	M					1	12/97

Doc. No.	Index	Issue	DE	FR	IT	GB	Seite/ Page/ Pagina/ Page							
76.9274.01		12/97	Baugruppe	Unité	Unità	Unit	5							
PEN-E			Kessel	Marmite	Marmitta	Kettle								

Pos.	Product No.	Service No.	Bezeichnung	Désignation	Designazione	Designation	Type	x	y	M	80	150	200	300	Introduc-tion
1	76.5014.01		Kessel	marmite	marmitta	kettle		800	700		1				12/97
	76.5014.02		Kessel	marmite	marmitta	kettle		800	700			1			12/97
	76.5014.03		Kessel	marmite	marmitta	kettle		800	700				1		12/97
	76.5014.04		Kessel	marmite	marmitta	kettle		800	700					1	12/97
	76.5014.05		Kessel	marmite	marmitta	kettle		900	700		1				12/97
	76.5014.06		Kessel	marmite	marmitta	kettle		900	700			1			12/97
	76.5014.07		Kessel	marmite	marmitta	kettle		900	700				1		12/97
	76.5014.08		Kessel	marmite	marmitta	kettle		900	700					1	12/97
	76.5014.09		Kessel	marmite	marmitta	kettle		800	700	M	1				12/97
	76.5014.10		Kessel	marmite	marmitta	kettle		800	700	M		1			12/97
	76.5014.11		Kessel	marmite	marmitta	kettle		800	700	M			1		12/97
	76.5014.12		Kessel	marmite	marmitta	kettle		800	700	M				1	12/97
	76.5014.13		Kessel	marmite	marmitta	kettle		900	700	M	1				12/97
	76.5014.14		Kessel	marmite	marmitta	kettle		900	700	M		1			12/97
	76.5014.15		Kessel	marmite	marmitta	kettle		900	700	M			1		12/97
	76.5014.16		Kessel	marmite	marmitta	kettle		900	700	M				1	12/97
	76.5014.21		Kessel	marmite	marmitta	kettle		800	800		1				12/97
	76.5014.22		Kessel	marmite	marmitta	kettle		800	800			1			12/97
	76.5014.23		Kessel	marmite	marmitta	kettle		800	800				1		12/97
	76.5014.24		Kessel	marmite	marmitta	kettle		800	800					1	12/97
	76.5014.25		Kessel	marmite	marmitta	kettle		900	800		1				12/97
	76.5014.26		Kessel	marmite	marmitta	kettle		900	800			1			12/97
	76.5014.27		Kessel	marmite	marmitta	kettle		900	800				1		12/97
	76.5014.28		Kessel	marmite	marmitta	kettle		900	800					1	12/97
	76.5014.29		Kessel	marmite	marmitta	kettle		800	800	M	1				12/97
	76.5014.30		Kessel	marmite	marmitta	kettle		800	800	M		1			12/97
	76.5014.31		Kessel	marmite	marmitta	kettle		800	800	M			1		12/97
	76.5014.32		Kessel	marmite	marmitta	kettle		800	800	M				1	12/97
	76.5014.33		Kessel	marmite	marmitta	kettle		900	800	M	1				12/97
	76.5014.34		Kessel	marmite	marmitta	kettle		900	800	M		1			12/97
	76.5014.35		Kessel	marmite	marmitta	kettle		900	800	M			1		12/97
	76.5014.36		Kessel	marmite	marmitta	kettle		900	800	M				1	12/97

Doc. No.	Index	Issue	DE	FR	IT	GB	Seite/ Page/ Pagina/ Page					
76.9274.01		12/97	Baugruppe	Unité	Unità	Unit	6					
PEN-S			Kessel	Marmite	Marmitta	Kettle						

Pos.	Product No.	Service No.	Bezeichnung	Désignation	Designazione	Designation	Type	x	y	M	80	150	200	300	Introduc-tion
1	76.5320.01		Kessel	marmite	marmitta	kettle		800	700		1				12/97
	76.5320.02		Kessel	marmite	marmitta	kettle		800	700			1			12/97
	76.5320.03		Kessel	marmite	marmitta	kettle		800	700				1		12/97
	76.5320.04		Kessel	marmite	marmitta	kettle		800	700					1	12/97
	76.5320.05		Kessel	marmite	marmitta	kettle		900	700		1				12/97
	76.5320.06		Kessel	marmite	marmitta	kettle		900	700			1			12/97
	76.5320.07		Kessel	marmite	marmitta	kettle		900	700				1		12/97
	76.5320.08		Kessel	marmite	marmitta	kettle		900	700					1	12/97
	76.5320.09		Kessel	marmite	marmitta	kettle		800	700	M	1				12/97
	76.5320.10		Kessel	marmite	marmitta	kettle		800	700	M		1			12/97
	76.5320.11		Kessel	marmite	marmitta	kettle		800	700	M			1		12/97
	76.5320.12		Kessel	marmite	marmitta	kettle		800	700	M				1	12/97
	76.5320.13		Kessel	marmite	marmitta	kettle		900	700	M	1				12/97
	76.5320.14		Kessel	marmite	marmitta	kettle		900	700	M		1			12/97
	76.5320.15		Kessel	marmite	marmitta	kettle		900	700	M			1		12/97
	76.5320.16		Kessel	marmite	marmitta	kettle		900	700	M				1	12/97
	76.5320.21		Kessel	marmite	marmitta	kettle		800	800		1				12/97
	76.5320.22		Kessel	marmite	marmitta	kettle		800	800			1			12/97
	76.5320.23		Kessel	marmite	marmitta	kettle		800	800				1		12/97
	76.5320.24		Kessel	marmite	marmitta	kettle		800	800					1	12/97
	76.5320.25		Kessel	marmite	marmitta	kettle		900	800		1				12/97
	76.5320.26		Kessel	marmite	marmitta	kettle		900	800			1			12/97
	76.5320.27		Kessel	marmite	marmitta	kettle		900	800				1		12/97
	76.5320.28		Kessel	marmite	marmitta	kettle		900	800					1	12/97
	76.5320.29		Kessel	marmite	marmitta	kettle		800	800	M	1				12/97
	76.5320.30		Kessel	marmite	marmitta	kettle		800	800	M		1			12/97
	76.5320.31		Kessel	marmite	marmitta	kettle		800	800	M			1		12/97
	76.5320.32		Kessel	marmite	marmitta	kettle		800	800	M				1	12/97
	76.5320.33		Kessel	marmite	marmitta	kettle		900	800	M	1				12/97
	76.5320.34		Kessel	marmite	marmitta	kettle		900	800	M		1			12/97
	76.5320.35		Kessel	marmite	marmitta	kettle		900	800	M			1		12/97
	76.5320.36		Kessel	marmite	marmitta	kettle		900	800	M				1	12/97

Doc. No.	Index	Issue	DE	FR	IT	GB	Seite/ Page/ Pagina/ Page					
76.9274.01		12/97	Baugruppe	Unité	Unità	Unit	8					
JPEN-E			Kessel	Marmite	Marmitta	Kettle						

Pos.	Product No.	Service No.	Bezeichnung	Désignation	Designazione	Designation	Type	x	y	M	80	150	200	300	400	Introduc-tion
1	76.5340.01		Kessel	marmite	marmitta	kettle		850	650		1					12/97
	76.5340.02		Kessel	marmite	marmitta	kettle		850	650			1				12/97
	76.5340.03		Kessel	marmite	marmitta	kettle		850	700				1			12/97
	76.5340.04		Kessel	marmite	marmitta	kettle		850	700					1		12/97
	76.5340.05		Kessel	marmite	marmitta	kettle		900	650		1					12/97
	76.5340.06		Kessel	marmite	marmitta	kettle		900	650			1				12/97
	76.5340.07		Kessel	marmite	marmitta	kettle		900	700				1			12/97
	76.5340.08		Kessel	marmite	marmitta	kettle		900	700					1		12/97
	76.5340.11		Kessel	marmite	marmitta	kettle		850	750		1					12/97
	76.5340.12		Kessel	marmite	marmitta	kettle		850	750			1				12/97
	76.5340.13		Kessel	marmite	marmitta	kettle		850	750				1			12/97
	76.5340.14		Kessel	marmite	marmitta	kettle		850	750					1		12/97
	76.5340.15		Kessel	marmite	marmitta	kettle		900	750		1					12/97
	76.5340.16		Kessel	marmite	marmitta	kettle		900	750			1				12/97
	76.5340.17		Kessel	marmite	marmitta	kettle		900	750				1			12/97
	76.5340.18		Kessel	marmite	marmitta	kettle		900	750					1		12/97

Doc. No.	Index	Issue	DE	FR	IT	GB	Seite/ Page/ Pagina/ Page			
76.9274.01		12/97	Baugruppe	Unité	Unità	Unit	9			
JPEN			Kessel	Marmite	Marmitta	Kettle				

Pos.	Product No.	Service No.	Bezeichnung	Désignation	Designazione	Designation	Type	x	y	M	80	150	200	300	400	Introduc-tion
2	76.5075		Verstärkung	renforcement	rinforzamento	reinforcement					1					12/97
	76.5080		Verstärkung	renforcement	rinforzamento	reinforcement						1	1			12/97
	76.5062		Verstärkung	renforcement	rinforzamento	reinforcement								1		12/97
3	76.5076		Verstärkung	renforcement	rinforzamento	reinforcement					1					12/97
	76.5081		Verstärkung	renforcement	rinforzamento	reinforcement						1	1			12/97
	76.5063		Verstärkung	renforcement	rinforzamento	reinforcement								1		12/97
4	712 044 120.05	1101 8576	Mutter	écrou	dado	nut	M5				8	11	11	16		12/97
5	76.5079		Schiene	rail	stecca	rail								2		12/97
6	712 044 120.05	1101 8576	Mutter	écrou	dado	nut	M6							28		12/97
7	76.5158.01		Führung	guide	guida	guide	800				1	1	1	1		12/97
	76.5159.01		Führung	guide	guida	guide	900				1	1	1	1		12/97
8	76.5158.02		Führung	guide	guida	guide	800				1	1	1	1		12/97
	76.5159.01		Führung	guide	guida	guide	900				1	1	1	1		12/97
9	1117 1119		Schlauch	tuyau flexible	tubo flessibile	hose	29/22x800				2	2	2	2		12/97
10	1103 1770		Bride	bride	brida	shackle					4	4	4	4		12/97
11	76.2136.XX		Isolation	isolation	isolamento	insulation					01	02	03	04		6/98
12	76.2137.XX		Isolation	isolation	isolamento	insulation					01	02	02	03		6/98

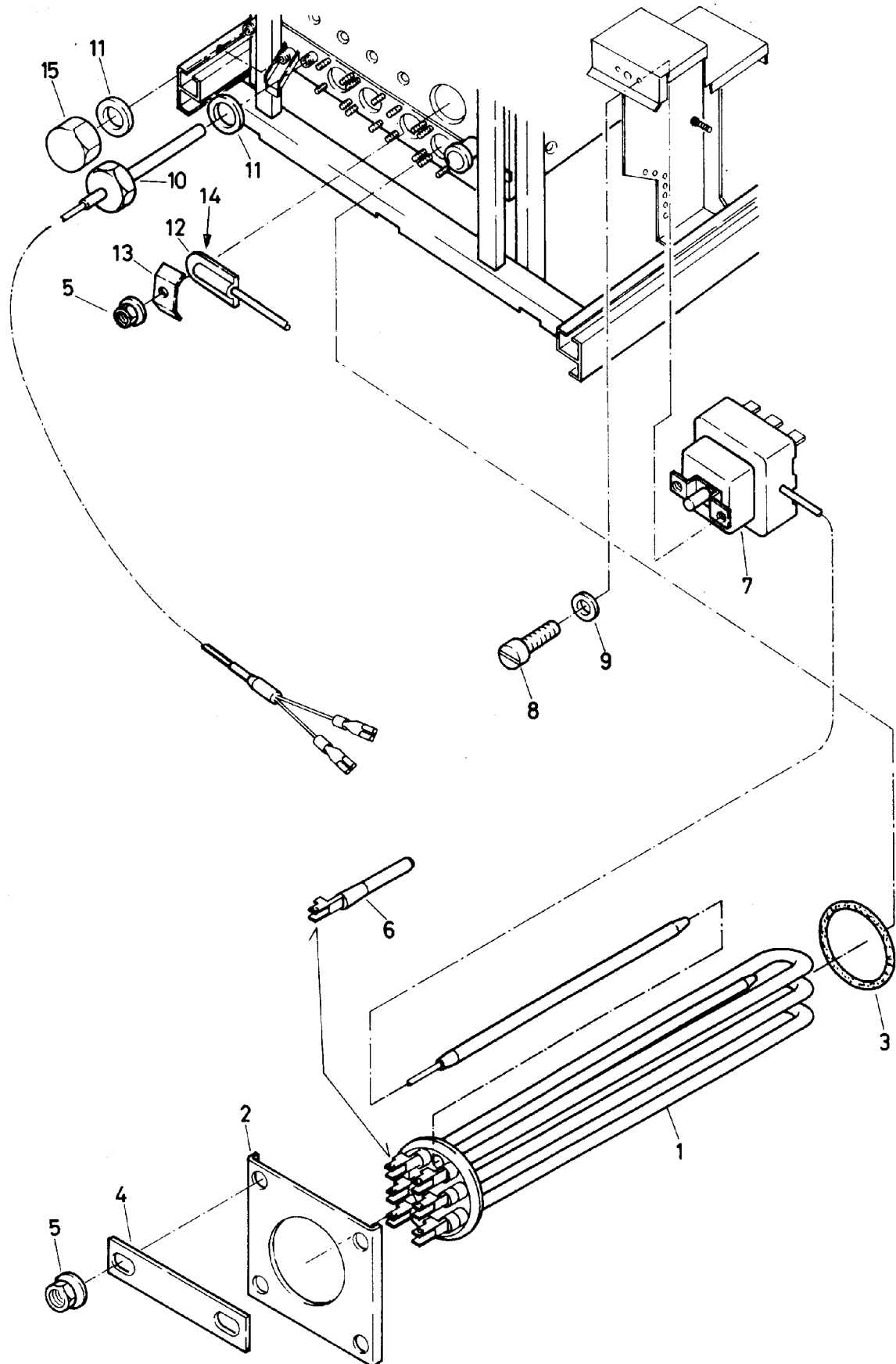

Doc. No.	Index	Issue	DE	FR	IT	GB	Seite/ Page/ Pagina/ Page					
76.9274.02		12/97	Baugruppe	Unité	Unità	Unit	1					
BEN (J)PEN			Heizung	chauffage	riscaldamento	heating						

Pos.	Product No.	Service No.	Bezeichnung	Désignation	Designazione	Designation	Type	80	150	200	300	400	Introduc-tion
1	76.3029.01		Heizung	chauffage	riscaldamento	heating	200V/3~	2	3	4		7	12/97
	76.3029.02		Heizung	chauffage	riscaldamento	heating	200V/3~	1	1	1		1	12/97
	76.3029.03	1800 1104	Heizung	chauffage	riscaldamento	heating	230V/3~	2	3	4		7	12/97
	76.3029.03	1800 1104	Heizung	chauffage	riscaldamento	heating	400V/3~	2	3	4		7	12/97
	76.3029.04	1800 1105	Heizung	chauffage	riscaldamento	heating	230V/3~	1	1	1		1	12/97
	76.3029.04	1800 1105	Heizung	chauffage	riscaldamento	heating	400V/3~	1	1	1		1	12/97
	76.3029.05		Heizung	chauffage	riscaldamento	heating	415V/3~	2	3	4		7	12/97
	76.3029.06		Heizung	chauffage	riscaldamento	heating	415V/3~	1	1	1		1	12/97
	76.3029.07		Heizung	chauffage	riscaldamento	heating	440V/3~	2	3	4		7	12/97
	76.3029.08		Heizung	chauffage	riscaldamento	heating	440V/3~	1	1	1		1	12/97
	76.3028.01		Heizung	chauffage	riscaldamento	heating	200V/3~				7		12/97
	76.3028.02		Heizung	chauffage	riscaldamento	heating	200V/3~				1		12/97
	76.3028.03	1800 1102	Heizung	chauffage	riscaldamento	heating	230V/3~				7		12/97
	76.3028.03	1800 1102	Heizung	chauffage	riscaldamento	heating	400V/3~				7		12/97
	76.3028.04	1800 1103	Heizung	chauffage	riscaldamento	heating	230V/3~				1		12/97
	76.3028.04	1800 1103	Heizung	chauffage	riscaldamento	heating	400 V/3~				1		12/97
	76.3028.05		Heizung	chauffage	riscaldamento	heating	415 V/3~				7		12/97
	76.3028.06		Heizung	chauffage	riscaldamento	heating	415V/3~				1		12/97
	76.3028.07		Heizung	chauffage	riscaldamento	heating	440V/3~				7		12/97
	76.3028.08		Heizung	chauffage	riscaldamento	heating	440V/3~				1		12/97
2	718 044 192	1800 2198	Halter	fixation	sostegno	support		3	4	5	8	8	12/97
3	718 042 198	1900 6668	Dichtung	joint	guarnizione	sealing		3	4	5	8	8	12/97
4	70.0534		Halter	fixation	sostegno	support		1	1	1	1	1	12/97
5	712 044 120.05	1101 8576	Mutter	écrou	dado	nut	M5	14	18	22	34	34	12/97
6	76.3049	1801 3708	Sicherung	fusible	fusibile	fuse		1	1	1	1	1	12/97
7	76.3033	1802 5561	Begrenzer	limiteur	limitatore	limiter		1	1	1	1	1	12/97
8	1701 2077		Schraube	vis	vite	screw	M4x6	2	2	2	2	2	12/97
9	1701 5002		Federring	anneau de ressort	anello di molla	spring ring	M4	2	2	2	2	2	12/97
10	76.3006	1802 5570	Fühler	sonde	seniore	sensor	Ø8x11	1	1	1	1	1	12/97
11	712 044 481.21	1900 6840	Dichtung	joint	guarnizione	sealing		1	1	1	1	1	12/97

Doc. No.	Index	Issue	DE	FR	IT	GB	Seite/ Page/ Pagina/ Page			
76.9274.02		12/97	Baugruppe	Unité	Unità	Unit	2			
BEN (J)PEN			Heizung	chauffage	riscaldamento	heating				

Pos.	Product No.	Service No.	Bezeichnung	Désignation	Designazione	Designation	Type	80	150	200	300	400	Introduc-tion
12	76.3005.01	1 802 5572	Fühler	sonde	sensore	sensor		1	1	1	1	1	12/97
13	76.4191	1802 5576	Halter	fixation	sostegno	support		1	1	1	1	1	12/97
14	1201 1510		Paste	pâte	pasta	paste		1	1	1	1	1	12/97
15	1701 3016	1101 8572	Mutter	écrou	dado	nut	M6x0.8	1	1	1	1	1	12/97
16	1701 5007		Federring	anneau de ressort	anello di molla	spring ring	M6	1	1	1	1	1	12/97
17	1701 4003		Unterlagscheibe	rondelle	rondella	washer	M6	1	1	1	1	1	12/97

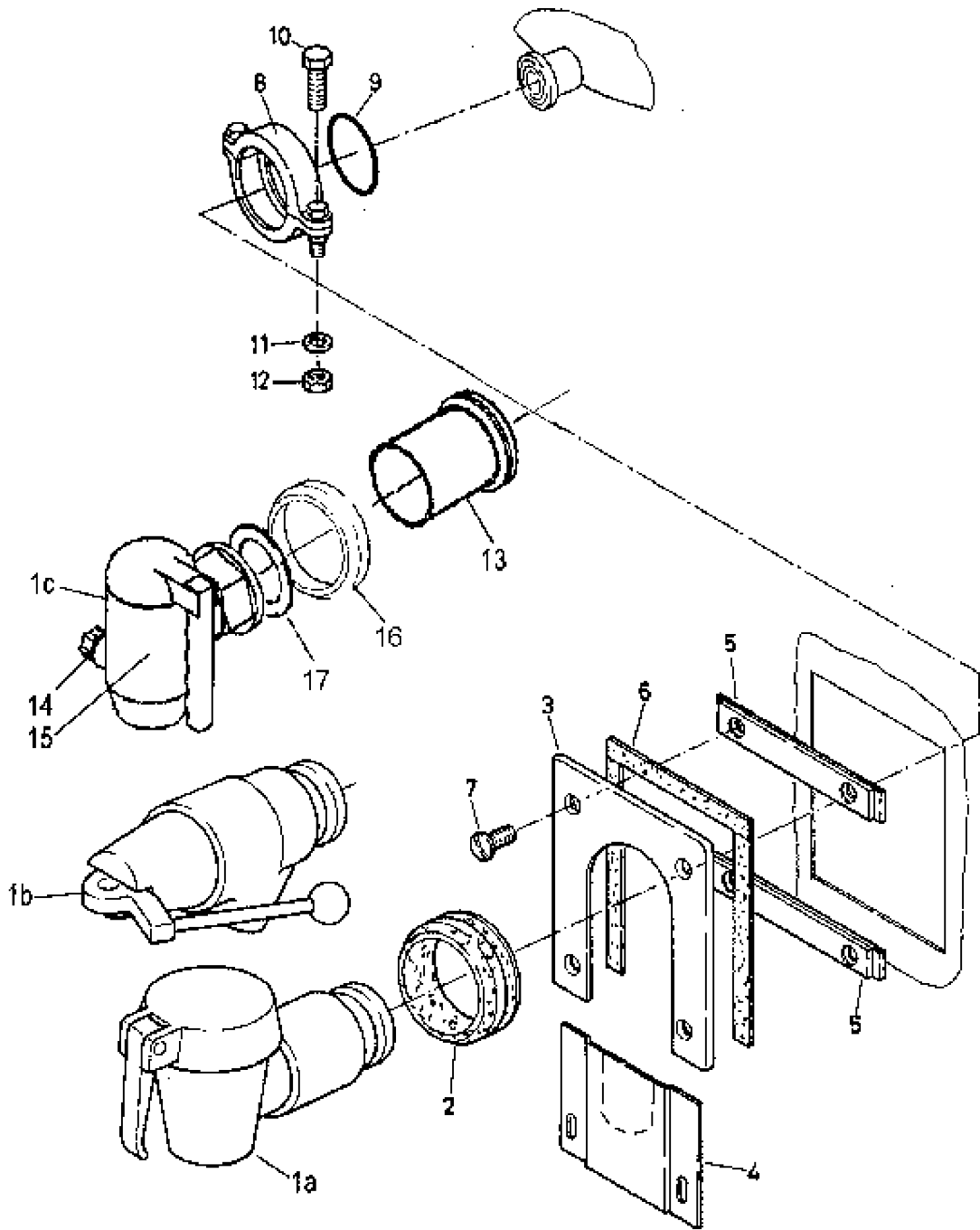

Doc. No.	Index	Issue	DE	FR	IT	GB	Seite/ Page/ Pagina/ Page			
76.9274.04		12/97	Baugruppe	Unité	Unità	Unit	1			
BEN (J)PEN			Auslaufhahn	Robinet	Rubinetto	Tap				

Pos.	Product No.	Service No.	Bezeichnung	Désignation	Designazione	Designation	Type		BON	BEN	(J)PEN	Introduction
1a	70.0493	1900 3246	Hahn	robinet	rubinetto	tap			1			12/97
	70.0434	1900 3268	Hahn	robinet	rubinetto	tap				1		12/97
1b	712 344 891	1900 3266	Hahn	robinet	rubinetto	tap					1	12/97
1c	1117 1258		Hahn	robinet	rubinetto	tap	2 "			1	1	04/03
2	70.1288.02	1900 3291	Dichtung	joint	guarnizione	sealing	1 ½"		1			12/97
	70.1288.01	1900 3296	Dichtung	joint	guarnizione	sealing	2 "			1	1	12/97
3	70.0693.01		Blech	tôle	lamiera	sheet			1			12/97
	70.0693.02		Blech	tôle	lamiera	sheet				1	1	12/97
4	70.0695.01		Blech	tôle	lamiera	sheet			1			12/97
	70.0695.02		Blech	tôle	lamiera	sheet				1	1	12/97
5	70.0691.XX		Flansch	bride	flangia	flange			2	2	2	12/97
6	1201 1522	1101 9072	Dichtung	joint	guarnizione	sealing			1	1	1	12/97
7	1701 1505		Schraube	vis	vite	screw	M4x10		4	4	4	12/97
8	713 842 019	1900 3373	Bride	bride	brida	shackle			1	1	1	12/97
9	713 042 130	1900 6833	O-Ring	joint torique	anello	o-ring			1	1	1	12/97
10	1701 2583		Schraube	vis	vite	screw	M8x40		1	1	1	12/97
11	1701 5008		Federring	anneau de ressort	anello di molla	spring ring	M8		1	1	1	12/97
12	1701 3044	1101 8573	Mutter	écrou	dado	nut	M8		1	1	1	12/97
13	76.3194		Übergangsstück	pièce de raccordement	pezzo di raccordo	reducing part			1	1	1	04/03
14	1117 1261		Verriegelungs-Einheit	unité de blocage	unita di bloccaggio	blockade kit			1	1	1	04.03
15	1201 2070		O-Ring	joint torique	anello	o-ring			3	3	3	04.03
16	1117 1262		Rosette	rosace	rosetta	rose				1	1	05/03
17	1 101 2192		Dichtung	joint	guarnizione	sealing			1	1	1	

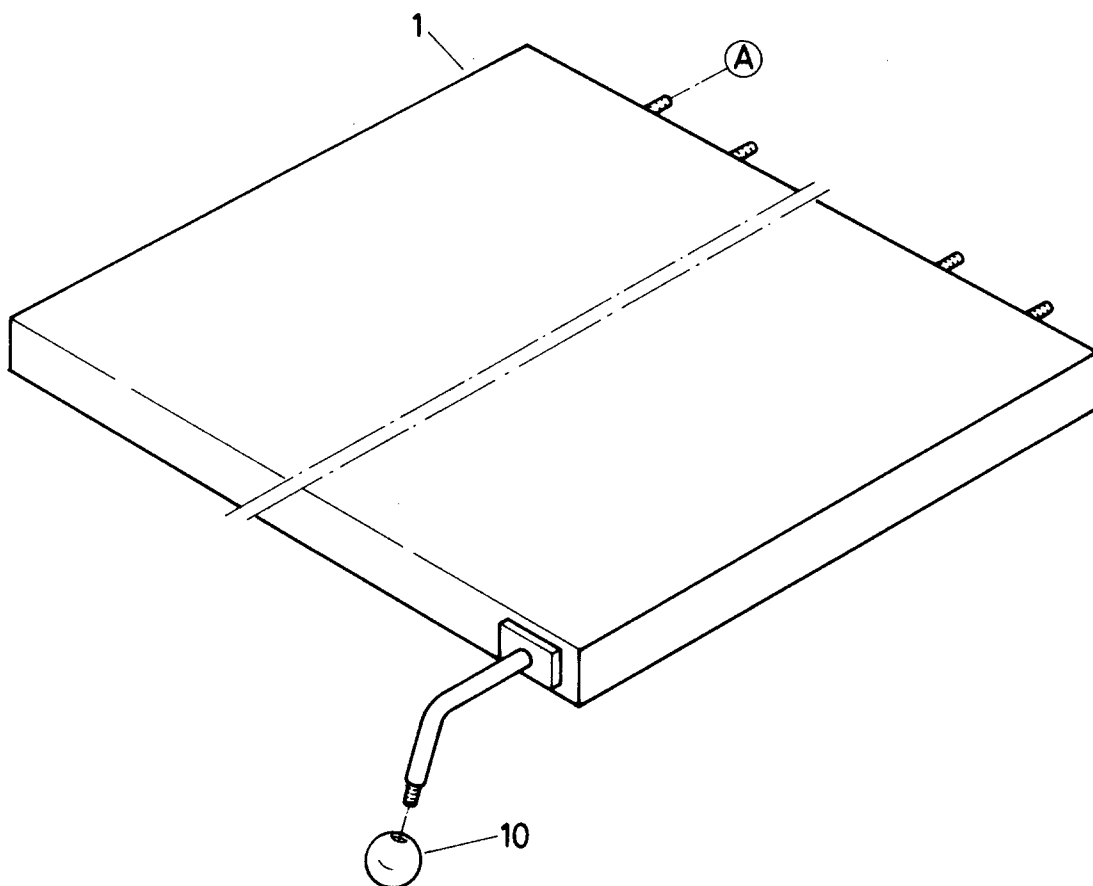
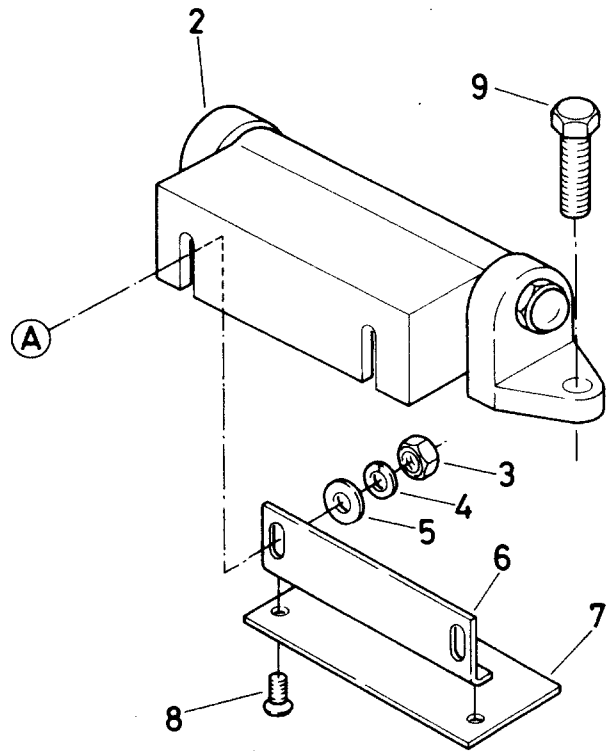

Doc. No.	Index	Issue	DE	FR	IT	GB	Seite/ Page/ Pagina/ Page			
76.9274.05		12/97	Baugruppe	Unité	Unità	Unit	1			
BEN			Deckel	couvercle	coperchio	lid				

Pos.	Product No.	Service No.	Bezeichnung	Désignation	Designazione	Designation	Type				Introduc-tion
1	70.1422.01		Deckel	couvercle	coperchio	lid	80l		1		12/97
	70.1422.02		Deckel	couvercle	coperchio	lid	150-200l		1		12/97
	70.1422.03		Deckel	couvercle	coperchio	lid	300l		1		12/97
	70.1422.04		Deckel	couvercle	coperchio	lid	400l		1		12/97
2	70.0750.03	1900 0769	Gelenk	genouillère	articolazione	joint	80/150/100l		1		12/97
	70.0750.05	1900 0765	Gelenk	genouillère	articolazione	joint	300-400l		2		12/97
3	1701 3044	1101 8573	Mutter	écrou	dado	nut	M8		2		12/97
4	1701 5008		Federring	anneau de ressort	anello di molla	spring ring	M8		2		12/97
5	1701 3513	1802 5481	Unterlagscheibe	rondelle	rondella	washer	M8		2		12/97
6	70.0764		Winkel	angle	angolo	angle			1		12/97
7	70.0765.01		Blech	tôle	lamiera	sheet			1		12/97
8	1701 1504		Schraube	vis	vite	screw	M4x8		2		12/97
9	1701 2541		Schraube	vis	vite	screw	M10x25		2		12/97
10	10.2673	1900 6078	Kugel	boule,	palla	ball			1		12/97

Doc. No.	Issue	DE	FR	IT	GB	Seite/ Page/ Pagina/ Page
76.9274.06	12/97	Baugruppe	Unité	Unità	Unit	1
(J)PEN		Druckdeckel	Couvercle à pression	Coperchio a pressione	Pressure lid	

Pos.	Product No.	Service No.	Bezeichnung	Désignation	Designazione	Designation	80	150	200	300	Introduction
	70.1444.XX		Deckel komplett	couvercle complet	coperchio completo	lid complete	01	02	02	03	12/97
300	70.1445.XX		Gehäuse	boîtier	base	housing	01	02	02	03	12/97
321	70.1101	1900 0622	Griffkonsole links	console de poignée gauche	mensola di manetta sinistra	knob console left	x	x	x	x	12/97
322	70.1102	1900 0623	Griffkonsole rechts	console de poignée droit	mensola di manetta destra	knob console right	x	x	x	x	12/97
323	712 344 733.10	1900 6078	Kugelgriff Ø45mm	poignée à boule	manetta a pomello	ball handle	x	x	x	x	12/97
324	70.1103.01	1901 6120	Griffstange 430 mm	tige de poignée	asta di manetta	handle rod	x				12/97
325	70.1103.02	1901 6121	Griffstange 760 mm	tige de poignée	asta di manetta	handle rod		x	x		12/97
326	70.1103.03	1901 6122	Griffstange 1130 mm	tige de poignée	asta di manetta	handle rod				x	12/97
327	718 034 000	1900 6885	Dichtung 676x448	joint	guarnizione	washer	x				12/97
328	718 034 001	1900 6886	Dichtung 676x778	joint	guarnizione	washer		x	x		12/97
329	718 034 002	1900 6887	Dichtung 676x1148	joint	guarnizione	washer				x	12/97
331	70.0179	1900 0775	Deckelzapfen	cheville de couvercle	zaffo di coperchio	lid stud	x	x	x		12/97
332	70.0164	1900 0776	Federeinbau rechts	encastrement à ressort droit	montaggio di molla destra	spring assembly right	x			x	12/97
333	70.0165	1900 0777	Federeinbau rechts	encastrement à ressort droit	montaggio di molla destra	spring assembly right		x	x		12/97
334	70.0166	1900 0779	Federeinbau links	encastrement à ressort gauche	montaggio di molla sinistra	spring assembly left				x	12/97
340	71.3155	1900 3983	Hinweisschild	panneau	targhetta	label	x	x	x	x	12/97
341	74.0467		Hinweisschild	panneau	targhetta	label	x	x	x	x	12/97
342	70.0170		Deckellager	palier de couvercle	cuscinetto di coperchio	lid bearing	x	x	x	x	12/97
344	1101 8145	1101 8145	Schraube M10x80	vis	vite	screw	x	x	x	x	12/97
345	1101 8117	1101 8117	Schraube M10x25	vis	vite	screw	x	x	x	x	12/97
346	1701 5038	1701 5038	Federring Ø10,2/16	anneau de ressort	anello di molla	spring ring	x	x	x	x	12/97
347	70.0395	1900 0689	Abschlussdeckel	couvercle de recouvrement	coperchio di chiusura	end cover	x	x	x	x	12/97

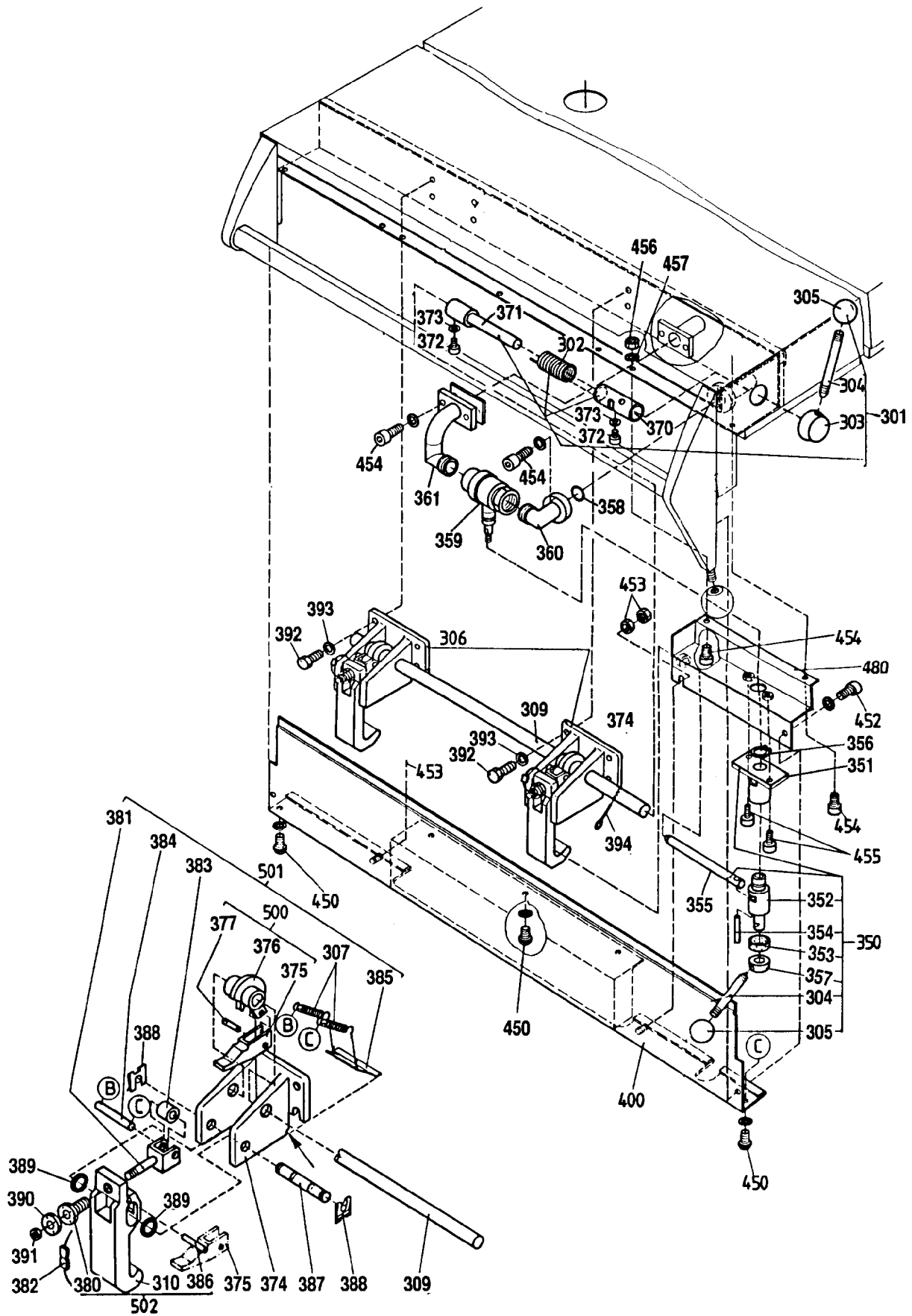

Doc. No.		Issue	DE	FR	IT	GB	Seite/ Page/ Pagina/ Page			
76.9274.07		12/97	Baugruppe	Unité	Unità	Unit	1			
(J)PEN			Druckdeckel- Verschluss	Verrouillage du couvercle à pression	Chiusura del coperchio a pressione	Pressure lid lock				

Pos.	Product No.	Service No.	Bezeichnung	Désignation	Designazione	Designation	80	150	200	300		Intro- duction
301	70.0122		Antrieb komplett	entraînement complet	azionamento completo	drive complete	x	x	x	x		12/97
302	712 044 851.01	1900 1667	Drehfeder	ressort de torsion	molla di rotazione	torsion spring	x	x	x	x		12/97
303	70.0128.01	1900 0762	Nabe	moyeu	mozzo	hub	x	x	x	x		08/97
	70.1574		Nabe neu	moyeu	mozzo	hub new	x	x	x	x		08/97
304	70.0139.01	1900 0747	Hebel Ø 8	levier	leva	lever	x	x	x	x		08/97
	70.0139.02		Hebel Ø 10 neu	levier	leva	lever new	x	x	x	x		08/97
305	712 344 733.06	1900 6076	Kugelgriff Ø28mm	poignée à boule	manetta a pomello	ball handle	x	x	x	x		12/97
306	70.0129		Verschlusseinheit komplett	unité de verrouillage complet	unità di chiusura completo	lock unit complete	x	x	x	x		12/97
307	70.0214	1900 1658	Feder	ressort	molla	spring	x	x	x	x		12/97
309	70.0131.01		Welle	axe	albero	shaft	x					12/97
	70.0131.02	1900 4273	Welle	axe	albero	shaft		x	x			12/97
	70.0131.03	1900 4274	Welle	axe	albero	shaft				x		12/97
310	70.0613		Verschlussshaken	crochet de fermeture	uncino	lock hook	x	x	x	x		12/97
370	70.0126		Kupplung	accouplement	agganciamento	coupling	x	x	x	x		12/97
371	70.0123		Welle	axe	albero	shaft	x	x	x	x		12/97
372	1101 8161	1101 8660	Schraube M6	vis	vite	screw	x	x	x	x		12/97
373	1701 5047		Federring M6	anneau de ressort	anello di molla	spring ring	x	x	x	x		12/97
374	70.0130		Lager	palier	cuscinetto	bearing	x	x	x	x		12/97
500	70.1375		Pos. 375, 376, 377				x	x	x	x		12/97
375	74.0199	1900 2490	Keil	clavette	cuneo	wedge	x	x	x	x		12/97
376	718 034 332		Exzenter	excentrique	eccentrico	eccentric	x	x	x	x		12/97
377	74.0176		Stift	broche	spina	pivot	x	x	x	x		12/97
380	70.1556	1900 2492	Stellschraube	vis de réglage	vite di regolazione	adjust screw	x	x	x	x		12/97
381	70.1555	1900 2491	Gabelzapfen	vis special	vite speciale	special screw	x	x	x	x		12/97
382	75.5004	1900 4279	Plombe	plomb	piomba	seal	x	x	x	x		12/97
383	718 044 108	1900 2493	Rolle	rouleau	puleggia	pulley	x	x	x	x		12/97
384	718 044 109	1900 2494	Bolzen	boulon	bolzone	bolt	x	x	x	x		12/97
385	70.0132		Lasche	languette	coprigiunto	latch	x	x	x	x		12/97

Doc. No.		Issue	DE	FR	IT	GB	Seite/ Page/ Pagina/ Page			
76.9274.07		12/97	Baugruppe	Unité	Unità	Unit	2			
(J)PEN			Druckdeckel- Verschluss	Verrouillage du couvercle à pression	Chiusura del coperchio a pressione	Pressure lid lock				

Pos.	Product No.	Service No.	Bezeichnung	Désignation	Designazione	Designation	80	150	200	300	Intro- duction
386	70.1344.01		Stift	broche	spina	pivot	x	x	x	x	12/97
387	70.0133		Bolzen	boulon	bolzone	bolt	x	x	x	x	12/97
388	712 345 082.12	1900 1221	Wellensicherung	sécurité d'axe	sicurezza dell'albero	shaft protection	x	x	x	x	12/97
	1 701 2775		Wellensicherung	sécurité d'axe	sicurezza dell'albero	shaft protection	x	x	x	x	46. week 2005
389	74.0148	1900 4289	Scheibe	disque	disco	disk	x	x	x	x	12/97
390	70.1557		Mutter	écrou	dado	nut	x	x	x	x	12/97
391	1701 3014	1101 8761	Kontermutter	contre-écrou	contro-dado	counter-nut	x	x	x	x	12/97
392	1101 8053	1101 8661	Schraube	vis	vite	screw	x	x	x	x	12/97
393	1701 5049		Scheibe	disque	disco	disk	x	x	x	x	12/97
394	1701 6016		Splint	goupille fendue	chiavetta	cotter	x	x	x	x	12/97
350 Pos. 351 - 357	71.3045	1900 1201	Hahntrieb komplett	entraînement du robinet complet	azionamento rubinetto completo	tap drive complete	x	x	x	x	12/97
358	712 044 481.04	1900 6862	Dichtung Ø24/17x2mm	joint	guarnizione	washer	x	x	x	x	12/97
359	75.7016	1900 3276?	Kugelhahn	robinet	valvola sferica	ball cock	x	x	x	x	12/97
360	71.3052		Rohrleitung	tuyauterie	tubo conduttore	pipe	x	x	x	x	12/97
361	71.3053		Rohrleitung	tuyauterie	tubo conduttore	pipe	x	x	x	x	12/97
400	70.1455		Frontblech	tôle frontale	lamiera frontale	front panel	x				12/97
	70.1492.01		Frontblech	tôle frontale	lamiera frontale	front panel		x	x		12/97
	70.1493.01		Frontblech	tôle frontale	lamiera frontale	front panel				x	12/97
450	GR 40 186.1		Spezialschraube	vis spécial	vite speciale	special screw	x	x	x	x	12/97
452	1701 2600		Schraube	vis	vite	screw	x	x	x	x	12/97
453	1116 1138		Kepsmutter	écrou	dado	capture nut	x	x	x	x	12/97
454	1101 8123		Schraube	vis	vite	screw	x	x	x	x	12/97
455	1101 8123		Schraube	vis	vite	screw	x	x	x	x	12/97

Doc. No.	Issue	DE	FR	IT	GB	Seite/ Page/ Pagina/ Page
76.9274.07	12/97	Baugruppe	Unité	Unità	Unit	3
(J)PEN		Druckdeckel- Verschluss	Verrouillage du couvercle à pression	Chiusura del coperchio a pressione	Pressure lid lock	

Pos.	Product No.	Service No.	Bezeichnung	Désignation	Designazione	Designation	80	150	200	300	Intro- duction
456	1101 8038		Mutter	écrou	dado	nut	x	x	x	x	12/97
457	1701 5047		Scheibe	disque	disco	disk	x	x	x	x	12/97
480	71.3044.01		Schutzblech links	tôle de protection gauche	lamiera di protezione sinistra	protection plate left	x	x	x	x	12/97
	71.3044.02		Schutzblech rechts	tôle de protection droit	lamiera di protezione destra	protection plate right	x	x	x	x	12/97
			Austauschsatz	garniture d'échange	guarnazione di ricambio	exchange kit					12/97
500			Exzenter	excentrique	eccentrico	eccentric					12/97
501			Verschlussatz	garniture de fermeture	unità dell'uncino	hook kit					12/97
502			Verschlusshaken	crochet de fermeture	uncino	lock hook					12/97
503			Verschlusseinheit	unité de verrouillage	unità di chiusura	lock unit					12/97

	1201 1547		Kleber Loctite 243	colle	colla	adhesive					12/97
	1101 8962		Schmiermittel Klüber UH1 84-201	lubrifiant	lubrificante	lubricant					12/97
	1101 8916		Antihaft-Spray Chesterton 725	spray antifriccion	spray antifrizione	antifriccion spray					12/97
	1201 1795		Antihaft-Spray Molykote 3402-C	spray antifriccion	spray antifrizione	antifriccion spray					12/97

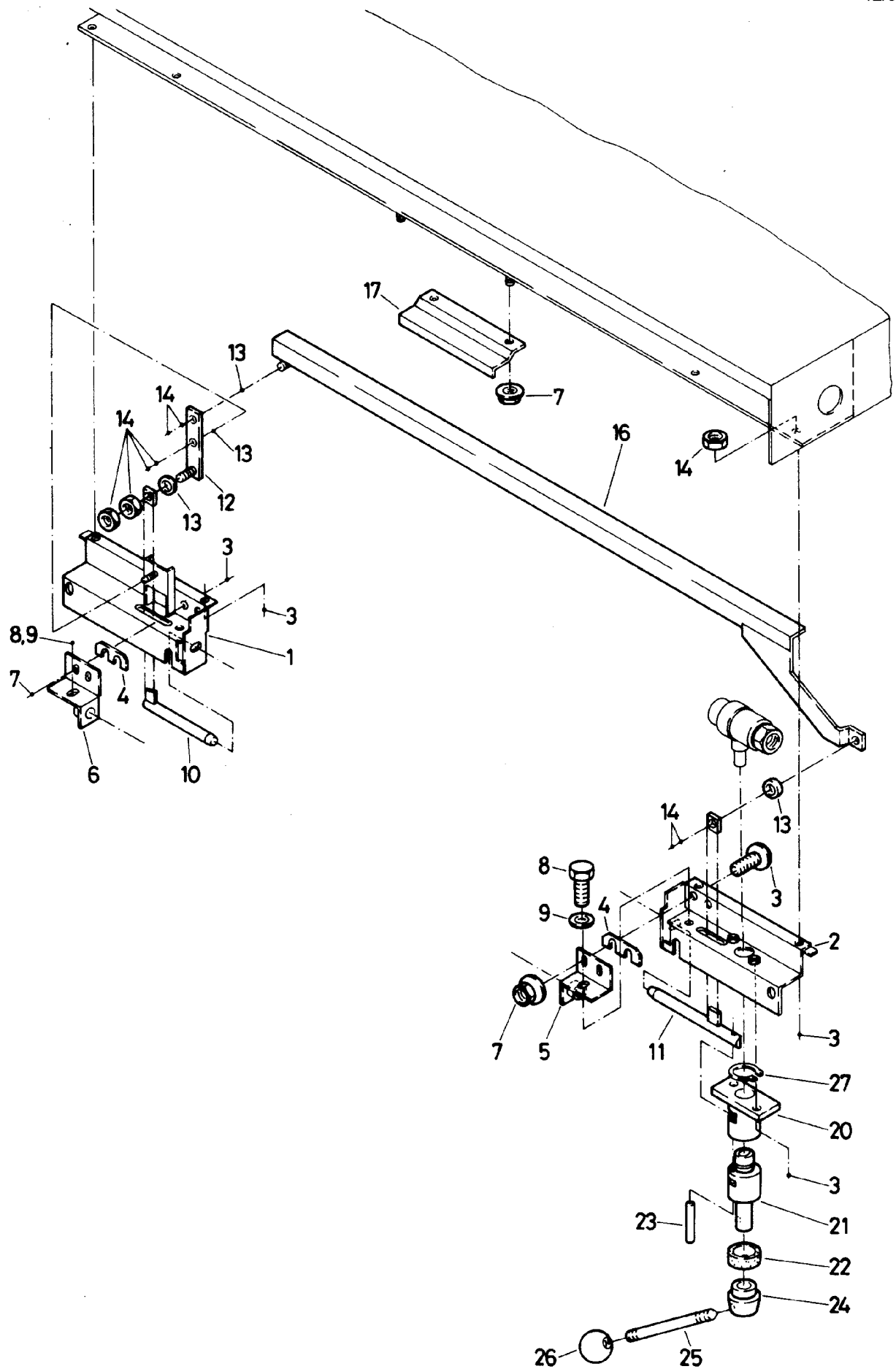

Doc. No.	Index	Issue	DE	FR	IT	GB	Seite/ Page/ Pagina/ Page		
76.9274.08		12/97	Baugruppe	Unité	Unità	Unit	1		
(J)PEN			Doppelsicherung	Sécurité double	Congegno doppio	Double securing			

Pos.	Product No.	Service No.	Bezeichnung	Désignation	Designazione	Designation	Type		Introduc-tion
2	70.1458.01		Blech links	tôle gauche	lamiera sinistra	sheet left		1	12/97
	70.1458.02		Blech rechts	tôle droit	lamiera destra	sheet right		1	12/97
3	GR40 186.1		Schraube	vis	vite	screw	M6x15	12	12/97
4	70.1514.01		Distanzplatte	plaque de distance	placca di distanza	spacer plate	1mm	2	12/97
	70.1514.02		Distanzplatte	plaque de distance	placca di distanza	spacer plate	0.5mm	2	12/97
5	70.1513.02		Winkel rechts	angle droit	angolo destra	angle right		1	12/97
6	70.1513.01		Winkel links	angle gauche	angolo sinistra	angle left		1	12/97
7	712 044 120.06	1101 8577	Mutter	écrou	dado	nut	M6	8	12/97
8	1701 2507		Schraube	vis	vite	screw	M5x10	2	12/97
9	1701 5007		Federring	anneau de ressort	anello di molla	spring ring	M5	2	12/97
10	71.3360		Schieber	curseur	cursore	draught valve		1	12/97
11	71.3045.06		Schieber	curseur	cursore	draught valve		1	12/97
12	71.3353		Hebel	levier	leva	lever		1	12/97
13	71.0142		Hülse	douille	guscio	sleeve		4	12/97
14	1701 3010	1 101 8579	Mutter	écrou	dado	nut	M6	12	12/97
16	71.3362.01		Verbindung	connexion	congiungimento	connection	150-200l	1	12/97
	71.3362.02		Verbindung	connexion	congiungimento	connection	300l	1	12/97
17	71.3355		Blech	tôle	lamiera	sheet		1	12/97
20	71.3045.01		Lager	palier	cuscinetto	bearing		1	12/97
21	71.3045.03		Welle	axe	albero	shaft		1	12/97
22	71.3045.09		Ring	anneau	anello	ring		1	12/97
23	1701 7055		Stift	broche	spina	pivot	Ø4x32	1	12/97
24	71.3045.07		Halter	fixation	sostegno	support		1	12/97
25	70.0139	1 900 0747	Bolzen	boulon	bolzone	bolt		1	12/97
26	712 344 742.11		Kugel	boule, sphère	palla	ball	Ø28	1	12/97
27	1701 5065		Seegerring	rondelle Seeger	anello	seeger circlip ring		1	12/97

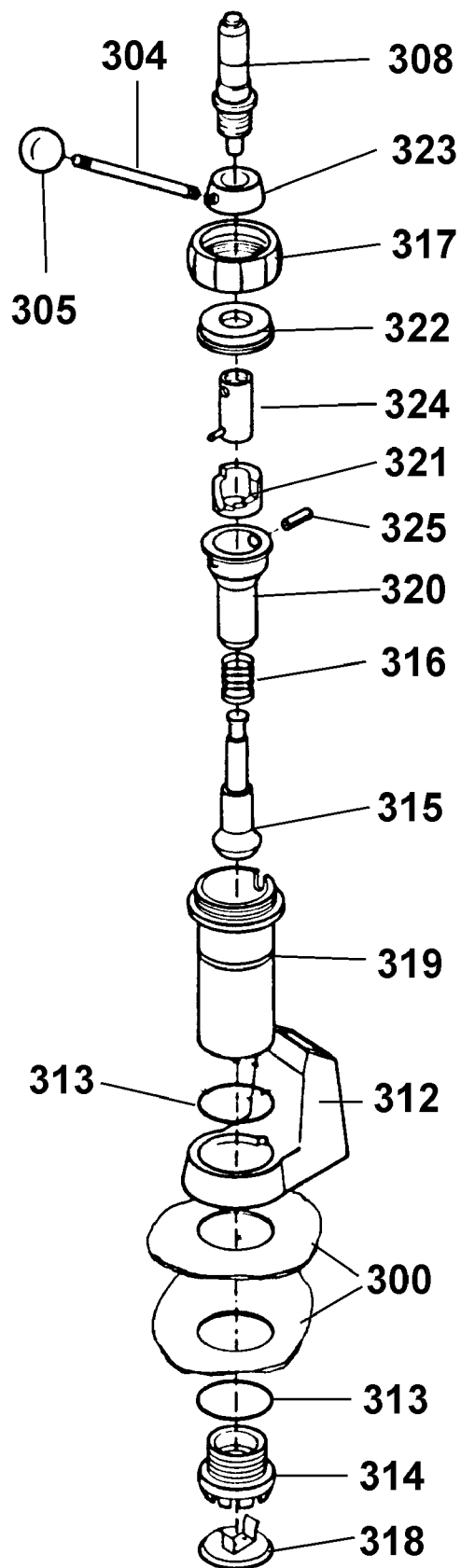

Doc. No.	Issue	DE	FR	IT	GB	Seite/ Page/ Pagina/ Page
76.9274.09	12/97	Baugruppe	Unité	Unità	Unit	1
(J)PEN		Deckelventil	Vanne de couvercle	Valvola di coperchio	Lid valve	

Pos.	Product No.	Service No.	Bezeichnung	Désignation	Designazione	Designation	80	150	200	300	Intro- duction
311	70.0144	1900 0675	Deckelventil komplett	vanne de couvercle complet	valvola di coperchio completo	lid valve complete	x	x	x	x	12/97
304	70.0139	1900 0747	Hebel	levier	leva	lever	x	x	x	x	12/97
305	712 344 733.06	1900 6076	Kugelgriff Ø28mm	poignée à boule	manetta a pomello	ball handle	x	x	x	x	12/97
308	70.1432		Druckanzeige komplett	indicateur de la pression complet	indicatore di pressione completo	pressure indicator complete	x	x	x	x	12/97
312	70.0140		Dampfabzug	départ de vapeur	scarico del vapore	steam outlet	x	x	x	x	12/97
313	712 044 480.01	1900 6654	O-Ring	joint torique	anello	o-ring	x	x	x	x	12/97
314	70.1502		Ventilsitz	siège de vanne	sede di valvola	valve seat	x	x	x	x	12/97
315	70.0149		Ventilkegel mit Bohrung	cône de vanne avec forure	cono di valvola con foro	valve cone with bore	x	x	x	x	12/97
316	70.0215		Feder	ressort	molla	spring	x	x	x	x	12/97
317	712 844 241	1900 3339	Ueberwurfmutter	écrou-raccord	dado a risvolto	union nut	x	x	x	x	12/97
318	70.1497	1900 5044	Dampfschikane	chicane de vapeur	lamiera di sviamento	steam baffle	x	x	x	x	12/97
319	70.0145		Gehäuse	bâti	base	housing	x	x	x	x	12/97
320	70.0147		Ventileinsatz	mécanisme de valve	femmina dell'animella	valve core	x	x	x	x	12/97
321	70.0148		Kurvenscheibe	disque	disco	disk	x	x	x	x	12/97
322	70.0150		Scheibe	disque	disco	disk	x	x	x	x	12/97
323	70.0128.02	1900 0763	Nabe mit Bohrung	moyeu avec forure	mozzo con foro	hub with bore	x	x	x	x	12/97
324	70.0151		Zylinder	cylindre	cilindro	cylinder	x	x	x	x	12/97
325	1701 7077		Stift	broche	spina	pivot	x	x	x	x	12/97

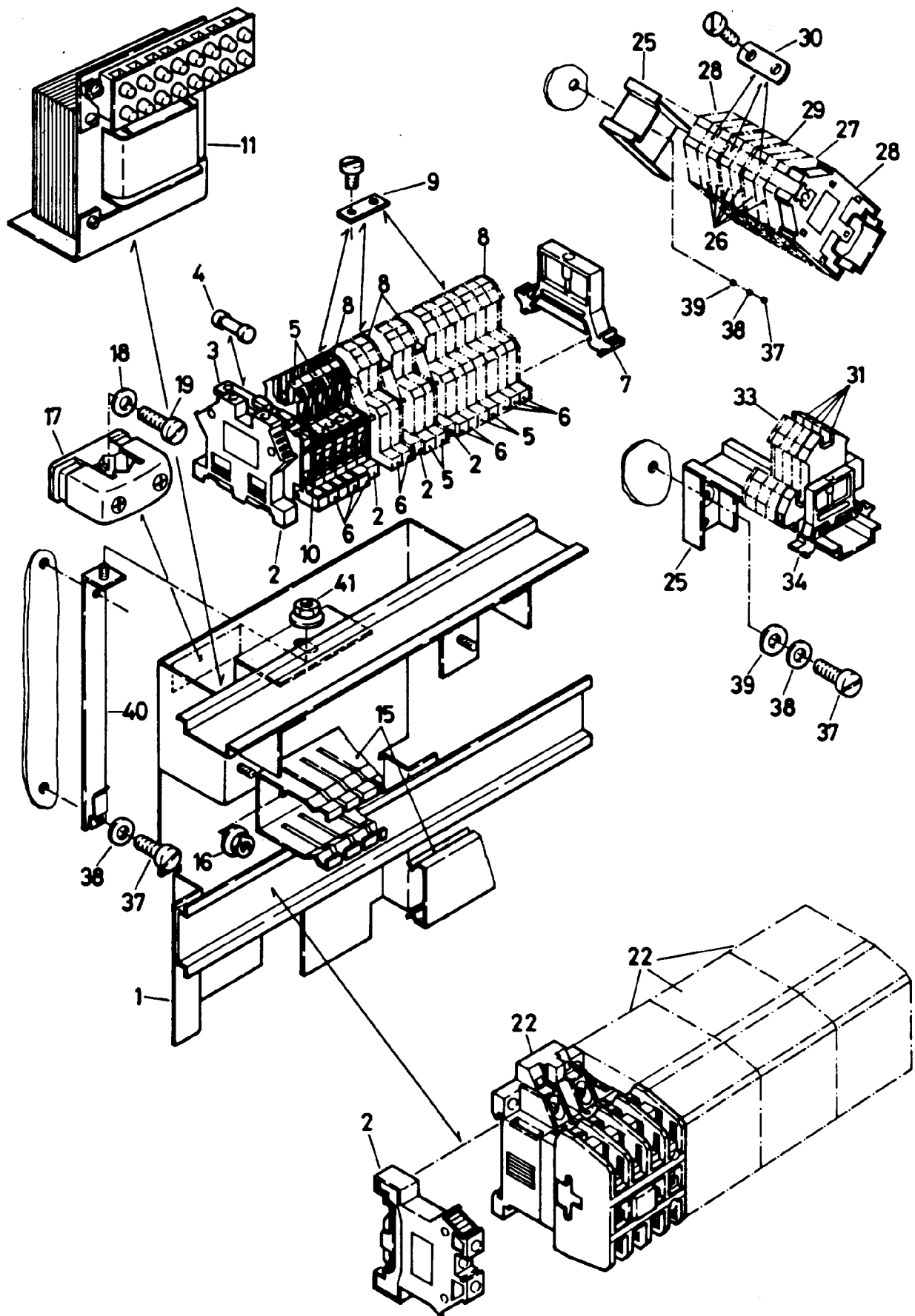

BEN/(J)PEN		Baugruppe Steuerung	unité commande	unità comando	unit control system	76.9274.10 1/2 12.97	
Pos.	Produkt Nr.	Service Nr.	Bezeichnung	désignation	designazione	designation	Type
1	76.9003		Träger	support	supporto	support	1
2	75.2011.01		Klemme	borne	morsa	terminal	5
3	75.2012.01	1802 5573	Klemme	borne	morsa	terminal	1-2
4	712 344362.01	1802 5574	Sicherung	fusible	fusibile	fuse	1
5	75.2010.11		Klemme	borne	morsa	terminal	5
6	75.2010.10		Klemme	borne	morsa	terminal	11
7	75.2013		Arretierstück	pièce d'arrête	parte d'arresto	stopper part	1
8	75.2010.12		Wand	cloison	parete	wall	4
9	75.2010.14		Verbindung	connexion	congiungimento	connection	3
10	75.2012.02		Wand	cloison	parete	wall	1-2
11	70.1371	1802 5441	Transformator	transformateur	trasformatore	transformer	200-440V 1
15	74.0216.03		Kanal	conduit	canale	channel	1
16	712 044120.06	1101 8511	Mutter	écrou	dado	nut	M6 2
17	1 116 1077	1801 5346	Bride	bride	brida	shackle	1
18	1 701 3502		Unterlagscheibe	rondelle	rondella	washer	Ø4.3x9 1
19	1 701 2021		Schraube	vis	vite	screw	M4x10 1
22	1115 1353	1800 5215	Schütz	contacteur-disjoncteur	contattore	contactor	12A 4
	1115 1355	1800 1117	Schütz	contacteur-disjoncteur	contattore	contactor	23A 4
25	76.9011.01		Halter	fixation	sostegno	support	80mm 1-2
	76.9011.02		Halter	fixation	sostegno	support	116mm 1-2
26	75.2010.30		Klemme	borne	morsa	terminal	6
	75.2010.40		Klemme	borne	morsa	terminal	6
27	75.2010.31		Klemme	borne	morsa	terminal	1
	75.2010.41		Klemme	borne	morsa	terminal	1
28	75.2011.02		Klemme	borne	morsa	terminal	2
	75.2011.03		Klemme	borne	morsa	terminal	2
29	75.2010.23		Wand	cloison	parete	wall	2
	75.2010.43		Wand	cloison	parete	wall	2
30	75.2010.34		Verbindung	connexion	congiungimento	connection	3
	75.2010.44		Verbindung	connexion	congiungimento	connection	3
31	75.2010.10		Klemme	borne	morsa	terminal	3

BEN/(J)PEN		Baugruppe Steuerung	unité commande	unità comando	unit control system	76.9274.10 2/2 12.97	
Pos.	Produkt Nr.	Service Nr.	Bezeichnung	désignation	designazione	designation	Type
32	75.2010.11		Klemme	borne	morsa	terminal	1
33	75.2010.12		Wand	cloison	parete	wall	1
34	75.2013		Arretierstück	piece d'arrête	parte d'arresto	stopper part	2
37	1031 79	1101 8605	Schraube	vis	vite	screw	M5x12 3
38	1 701 5004		Federring	anneau de ressort	anello di molla	spring ring	M5 3
39	1 701 3535		Scheibe	disque	disco	disk	M5 2
40	76.0034		Halter	fixation	sostegno	support	1
41	712 044120.05	1101 8576	Mutter	écrou	dado	nut	M5 1

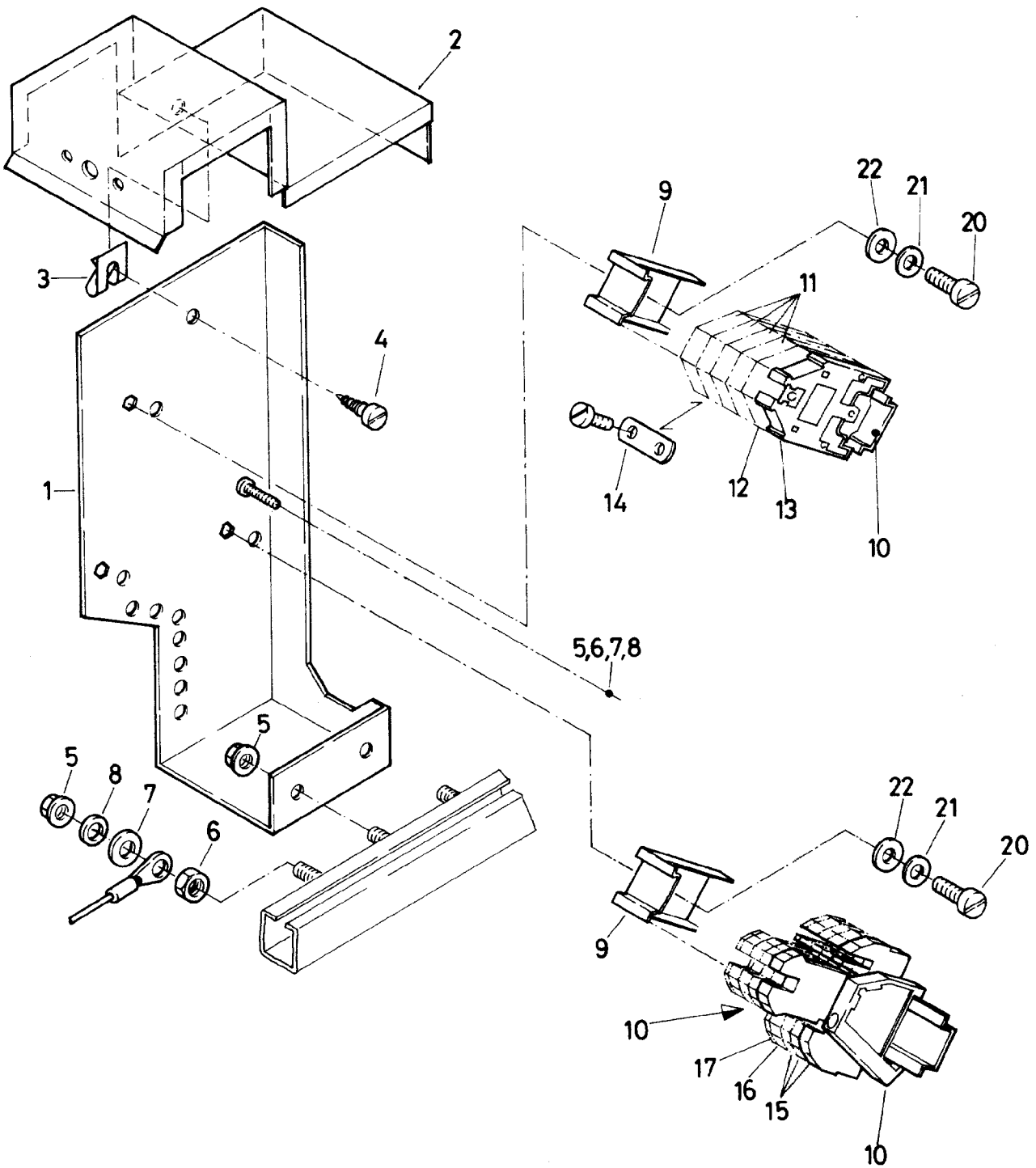

Doc. No.	Index	Issue	DE	FR	IT	GB	Seite/ Page/ Pagina/ Page			
76.9274.13		12/97	Baugruppe	Unité	Unità	Unit	1			
BEN (J)PEN			Elektroanschluss	raccordement électrique	collegamento elettrico	electric connection				

Pos.	Product No.	Service No.	Bezeichnung	Désignation	Designazione	Designation	Type			Introduc- -tion
1	76.9221		Halter	fixation	sostegno	support			1	12/97
2	76.9222		Abdeckung	couvercle	copertura	cover			1	12/97
3	712 044 121.01	1900 1235	Mutter	écrou	dado	nut	Ø4.8		1	12/97
4	1701 7539		Schraube	vis	vite	screw	4.8x13		1	12/97
5	712 044 120.06	1101 8577	Mutter	écrou	dado	nut	M6		4	12/97
6	1701 3016	1101 8572	Mutter	écrou	dado	nut	M6		2	12/97
7	1701 4003		Scheibe	disque	disco	disk	M6		2	12/97
8	1701 5007		Federring	anneau de ressort	anello di molla	spring ring	M6		2	12/97
9	76.9011.01		Halter	fixation	sostegno	support			2	12/97
10	76.2013		Arretierstück	piece d'arrête	parte d'arresto	stopper part			3	12/97
11	75.2010.40		Klemme	borne	morsa	terminal			4	12/97
	75.2010.50		Klemme	borne	morsa	terminal			4	12/97
12	75.2010.41		Klemme	borne	morsa	terminal			1	12/97
13	75.2011.03		Klemme	borne	morsa	terminal			1	12/97
	75.2011.04		Klemme	borne	morsa	terminal			1	12/97
14	75.2010.44		Verbindung	connexion	congiungimento	connection			1	12/97
	75.2010.54		Verbindung	connexion	congiungimento	connection			1	12/97
15	75.2011.10		Klemme	borne	morsa	terminal			3	12/97
16	75.2011.11		Klemme	borne	morsa	terminal			1	12/97
17	75.2011.12		Wand	cloison	parete	wall			1	12/97
20	10.3179		Schraube	vis	vite	screw	M5x12		2	12/97
21	1701 5004		Federring	anneau de ressort	anello di molla	spring ring	M5		2	12/97
22	1701 3535		Unterlagscheibe	rondelle	rondella	washer	M5		2	12/97

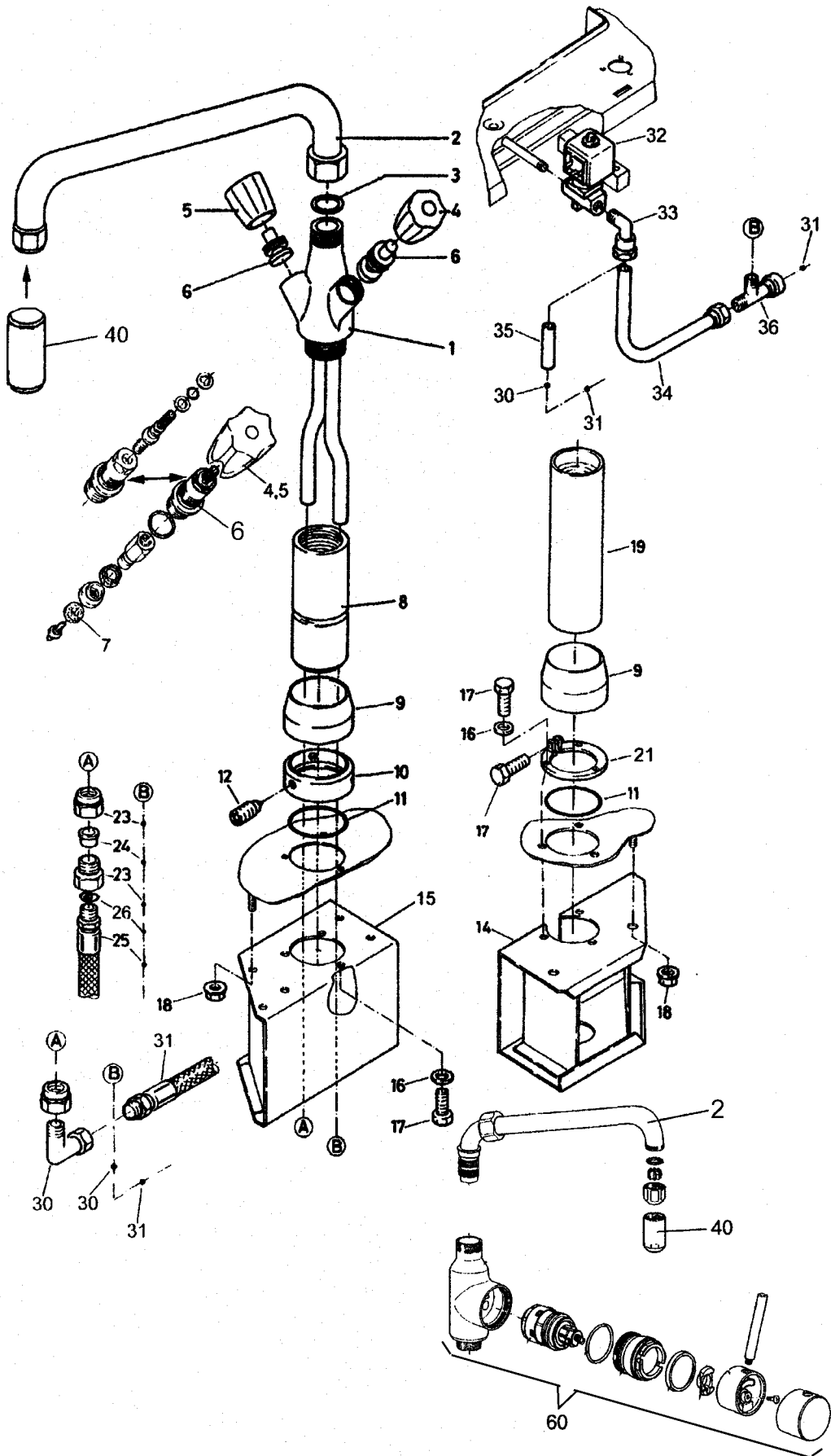

Doc. No.	Index	Issue	DE	FR	IT	GB	Seite/ Page/ Pagina/ Page					
76.9274.17		12/97	Baugruppe	Unité	Unità	Unit	1					
BEN PEN			Mischbatterie THERMA	batterie mélangeuse THERMA	Batteria THERMA	mixing unit THERMA						

Pos.	Product No.	Service No.	Bezeichnung	Désignation	Designazione	Designation	Type							Introduction
1	712 344 884.01	1900 3024	Mischbatterie komplett	batterie mélangeuse complet	batteria completo	mixing unit complete							1	12/97
2	712 344 884.02	1900 3119	Schwenkrohr	tuyau pivotant	tubo orientabile	swivel tube	300mm						1	12/97
	712 344 884.04	1900 3119	Schwenkrohr	tuyau pivotant	tubo orientabile	swivel tube	600mm							12/97
	712 344 884.03		Schwenkrohr	tuyau pivotant	tubo orientabile	swivel tube	450mm							12/97
3		1900 6781	Dichtung	joint	guarnizione	sealing							1	12/97
4		1900 6143	Griff blau	poignée bleu	manetta blu	knob blue	black						1	12/97
		KWC Z503.009.000	Griff blau	poignée bleu	manetta blu	knob blue	metallic						1	02/01
5		1900 6144	Griff rot	poignée rouge	manetta rosso	knob red	black						1	12/97
		KWC Z503.008.000	Griff rot	poignée rouge	manetta rosso	knob red	metallic						1	02/01
6		1900 3084	Ventileinsatz komplett	mécanisme de valve complet	femmina dell'animella completo	valve core complete							2	12/97
7		1900 6730	Dichtung	joint	guarnizione	sealing							2	12/97
8	72.0318.03		Standrohr	tuyau de vidange	tubo verticale	standing pipe	160mm						1	12/97
9	72.0435		Abdeckung	couvercle	copertura	cover							1	12/97
10	72.0450		Haltering	anneau de fixation	anello di sostegno	retaining ring							1	12/97
11	712 044 480.14		O-Ring	joint torique	anello	o-ring	2/53/57						1	12/97
12	1701 5524	1900 6959	Schraube	vis	vite	screw	M8x12						3	12/97
15	76.0117		Konsole	console	mensola	console							1	12/97
16	1701 5004		Federring	anneau de ressort	anello di molla	spring ring	M5						3	12/97
17	1701 2632		Schraube	vis	vite	screw	M4x16						3	12/97
18	712 044 120.05	1101 8576	Mutter	écrou	dado	nut	M5						4	12/97

Doc. No.	Index	Issue	DE	FR	IT	GB	Seite/ Page/ Pagina/ Page				
76.9274.17		12/97	Baugruppe	Unité	Unità	Unit	2				
BEN			Mischbatterie	mitigeur	batteria	mixing unit					
PEN											

Pos.	Product No.	Service No.	Bezeichnung	Désignation	Designazione	Designation	Type						Introduction
23	1101 3795		Nippel	mamelon	raccordo	nipple	1/2"					2	12/97
24	1101 3797	1900 6958	Hülse	douille	guscio	sleeve						2	12/97
25	712 344 893.02	1900 3189	Schlauch	tuyau flexible	tubo flessibile	hose						2	12/97
26	712 044 481.21		Dichtung	joint	guarnizione	washer						2	12/97
30	1101 2109		Winkel	angle	angolo	angle						2	12/97
31	712 344 894	1 900 3193	Schlauch	tuyau flexible	tubo flessibile	hose						2	12/97
32	76.3048	1 900 2498	Ventil	soupape, vanne	valvola	valve						1	12/97
32a	76.4935	1800 5648	Stecker	fiche	spina	plug						1	12/97
32b	76.9064.02		Kabel	câble	cavo	cable						1	12/97
33	1101 2138		Winkel	angle	angolo	angle						1	12/97
34	76.5266.01		Leitung	conduite	conduttura	conduit						1	12/97
35	76.5266.02		Leitung	conduite	conduttura	conduit						1	12/97
36	1101 2139		T-Stück	pièce en T	pezzo a T	T-part						1	12/97

14	76.4981		Konsole	console	mensola	console						1	09/99
19	76.5976.03		Standrohr	tuyau de vidange	tubo verticale	standing pipe	160mm					1	09/99
21	76.5919		Haltering	anneau de fixation	anello di sostegno	retaining ring						1	09/99

40	1105 1251		Tropfverhinderer	anti gouttes	antigocce	drip stop						1	03/00
60	712 344 884.05		Hebelmischer komplett	mitigeur à levier complet	miscelatori a leva completo	mixer unit with lever complete						1	1999

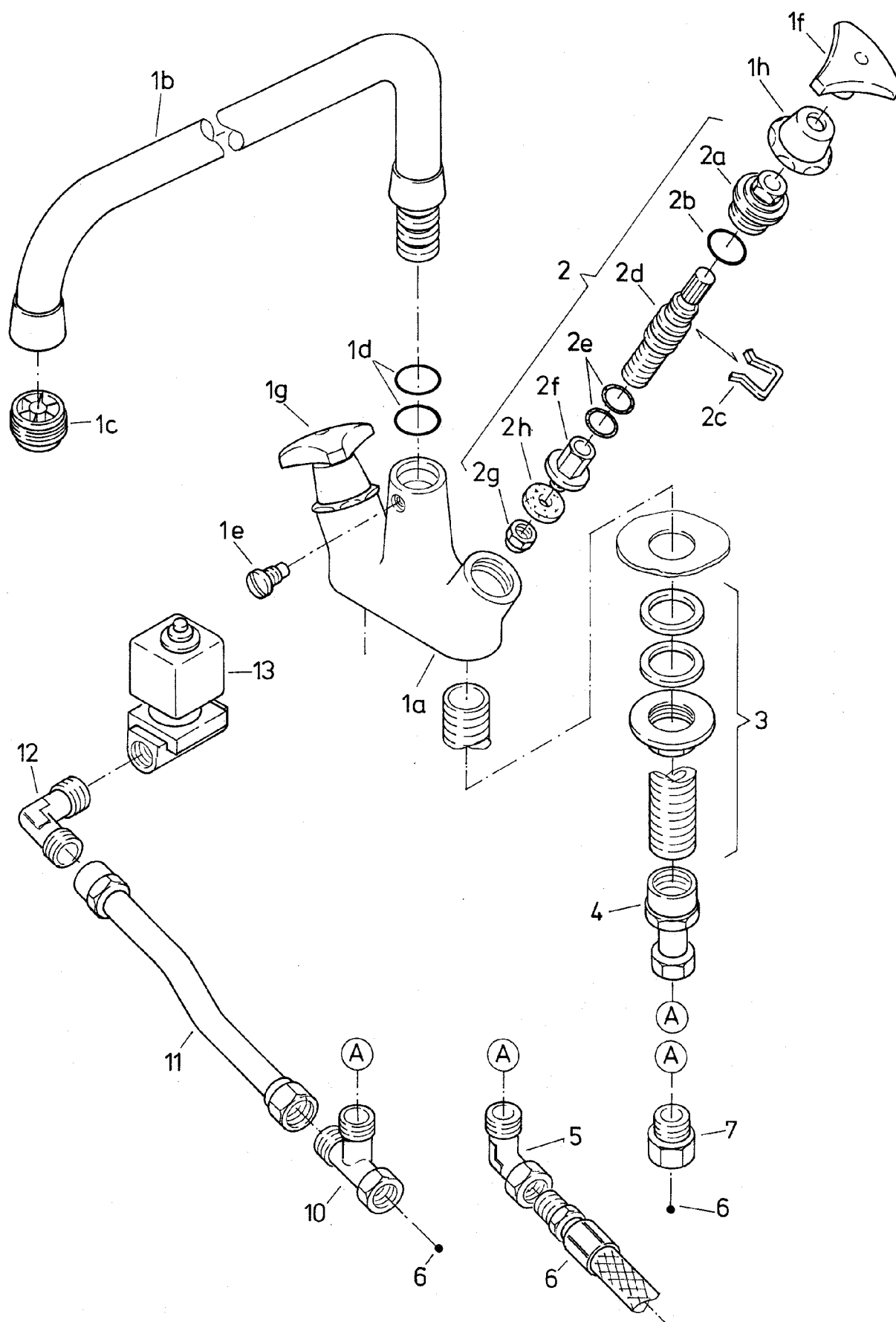

Doc. No.	Index	Issue	DE	FR	IT	GB	Seite/ Page/ Pagina/ Page		
76.9274.17a		12/97	Baugruppe	Unité	Unità	Unit	1		
JPEN			Mischbatterie JUNO	batterie mélangeuse JUNO	batteria JUNO	mixing unit JUNO			

Pos.	Product No.	Service No.	Bezeichnung	Désignation	Designazione	Designation	Type			Introduction
1	1105 1252		Mischbatterie komplett	batterie mélangeuse complet	batteria completo	mixing unit complete		1		12/97
1a			Gehäuse	boîtier	base	housing		1		12/97
1b			Schwenkrohr	tuyau pivotant	tubo orientabile	swivel tube		1		12/97
1c			Strahlbrecher	brise-jet	interruttore di getti	beam deflector		1		12/97
1d			O-Ring	joint torique	anello	o-ring		2		12/97
1e			Schraube	vis	vite	screw		1		12/97
1f			Griff blau	poignée bleu	manetta blu	knob blue		1		12/97
1g			Griff rot	poignée rouge	manetta rosso	knob red		1		12/97
1h			Kappe	capuchon	cappa	cap		2		12/97
2			Ventileinsatz komplett	mécanisme de valve complet	femmina dell'animella completo	valve core complete		2		12/97
2a			Käfig	cage	gabbia	cage		2		12/97
2b			O-Ring	joint torique	anello	o-ring		1		12/97
2c			Sicherungsring	anneau de sécurité	anello di fusibile	retaining ring		2		12/97
2d			Spindel	broche	asta	spindle		2		12/97
2e			O-Ring	joint torique	anello	o-ring		4		12/97
2f			Kolben	piston	pistone	piston		2		12/97
2g			Mutter	écrou	dado	nut		2		12/97
2h			Dichtung	joint	guarnizione	sealing		2		12/97
3	1201 1957		Montageteile	pièces de montage	pezzi di montaggio	mounting parts		2		12/97
4	1101 3902		Muffe	manchon	manicotto	muff		2		12/97
5	1101 2109		Winkel	angle	angolo	angle		2		12/97
6	712 344 894	1900 3193	Schlauch	tuyau flexible	tubo flessibile	hose		2(1)		12/97
10	1101 2139		T-Stück	pièce en T	pezzo a T	T-part		1		12/97
11	76.5372		Leitung	conduite	conduttura	conduit		1		12/97
12	1101 2138		Winkel	angle	angolo	angle		1		12/97
13	76.3048	1 900 2498	Ventil	soupape	valvola	valve		1		12/97
13a	76.4935	1800 5648	Stecker	fiche	spina	plug		1		12/97
13b	76.9193.01		Kabel	câble	cavo	cable		1		12/97
14	1201 1813		Loctite 577							12/97

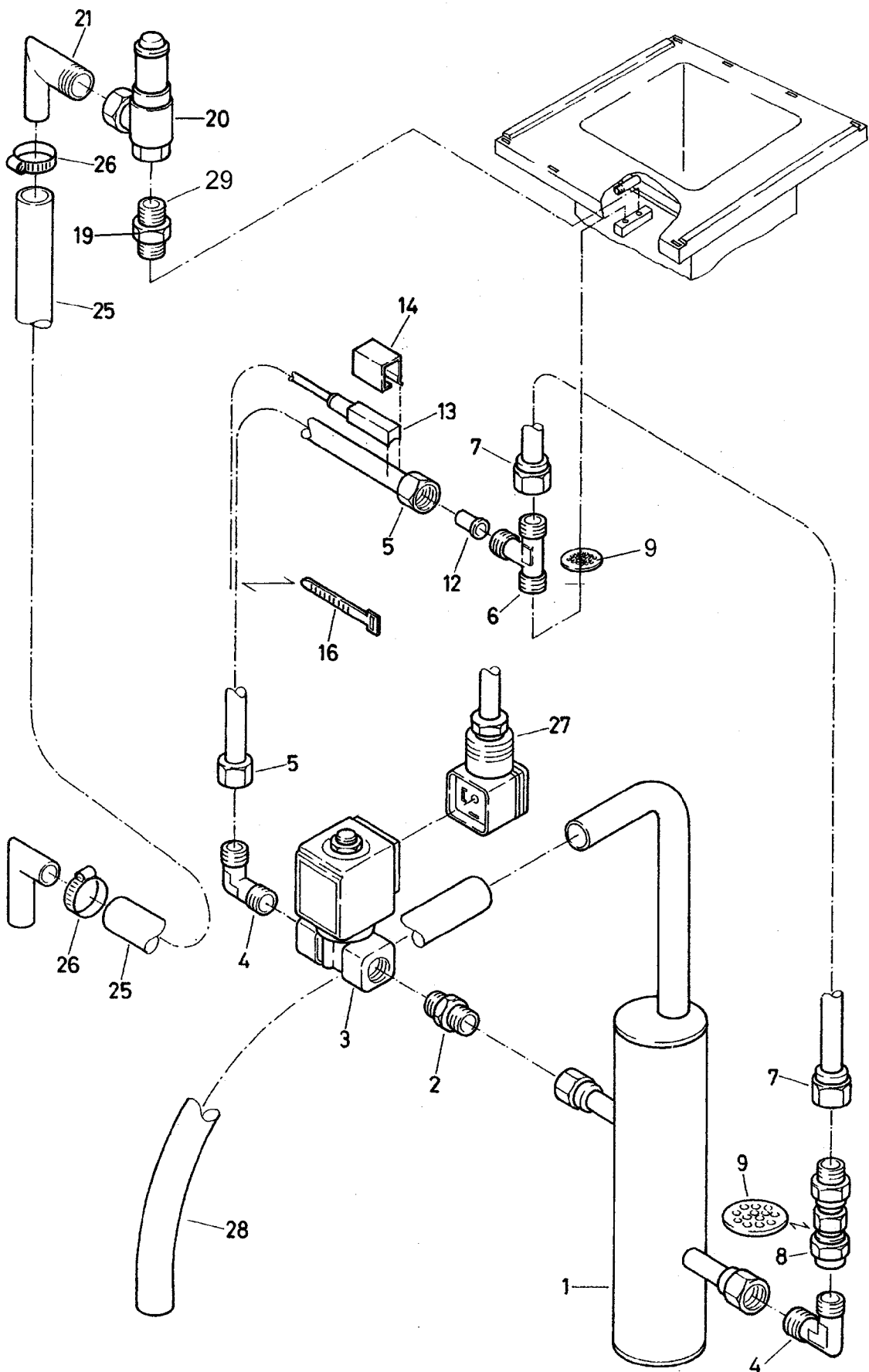

Doc. No.	Index	Issue	DE	FR	IT	GB	Seite/ Page/ Pagina/ Page		
76.9274.18		12/97	Baugruppe	Unité	Unità	Unit	1		
BEN-E,H (J)PEN-E,H			Entlüftung	deaération	deaereazione	deaeration			

Pos.	Product No.	Service No.	Bezeichnung	Désignation	Designazione	Designation	Type		Introduction
	76.5263		Entlüftung komplett	deaération complet	deaereazione completo	deaeration complete		1	09/97
1	76.4270.01		Kondensator	condenseur	condensatore	condenser		1	12/97
2	1101 3901		Nippel	mamelon	raccordo	nipple		1	12/97
3	76.3035	1900 2497	Solenoidventil	vanne solénoïde	elettrovalvola	solenoid valve		1	12/97
4	1101 3757		Winkel	angle	angolo	angle		2	12/97
5	76.5264.02		Leitung	conduite	conduttura	conduit		1	12/97
6	1101 3892		Verschraubung	vissage	collegamento	screwing		1	12/97
7	76.5264.01		Leitung	conduite	conduttura	conduit		1	12/97
8	1101 2136	1900 2495	Rückschlagventil	soupape anti-retour	valvola antiritorno	check valve		1	12/97
9	76.3061	1900 6974	Filter	filtre	filtro	filter		2	12/97
11	1201 1510		Paste	pâte	pasta	paste		1	12/97
12	1101 3747		Hülse	douille	guscio	sleeve		1	12/97
13	76.3062	1802 5575	Fühler	sonde	sensore	sensor		1	12/97
14	76.4191	1802 5576	Klammer	crampon	grappa	clamp		1	12/97
16	1115 1235		Kabelbride	bride pour câble	brida di cavo	cable clamp		3	12/97
19	1117 1192		Verschraubung	vissage	collegamento	screwing		1	12/97
20	75.7000.02	1900 2496	Sicherheitsventil	soupape de sécurité	valvola di sicurezza	safety valve		1	12/97
	76.4462	1900 2496	Sicherheitsventil	soupape de sécurité	valvola di sicurezza	safety valve		1	05/99
21	76.4365		Winkel	angle	angolo	angle		1	12/97
25	1115 1417	1901 6160	Schlauch	tuyau flexible	tubo flessibile	hose		1	12/97
26	1103 1170		Bride	bride	brida	shackle		6	12/97
27	76.4935	1800 5648	Stecker	fiche, connecteur	spina	plug		1	12/97
27a	76.9193.01		Kabel	câble	cavo	cable		1	12/97
28	12.9043	1900 3185	Schlauch	tuyau flexible	tubo flessibile	hose	Ø14/10x600	1	12/97
29	21 775		Teflonband	ruban en téflon	nastro di teflon	teflon band		1	09/00
30	1117 1239		Stopfen	bouchon	tappo	plug		1	09/98
31	1101 2157		Ring	anneau	anello	ring		1	09/98
32			Loctite 577					1	09/98

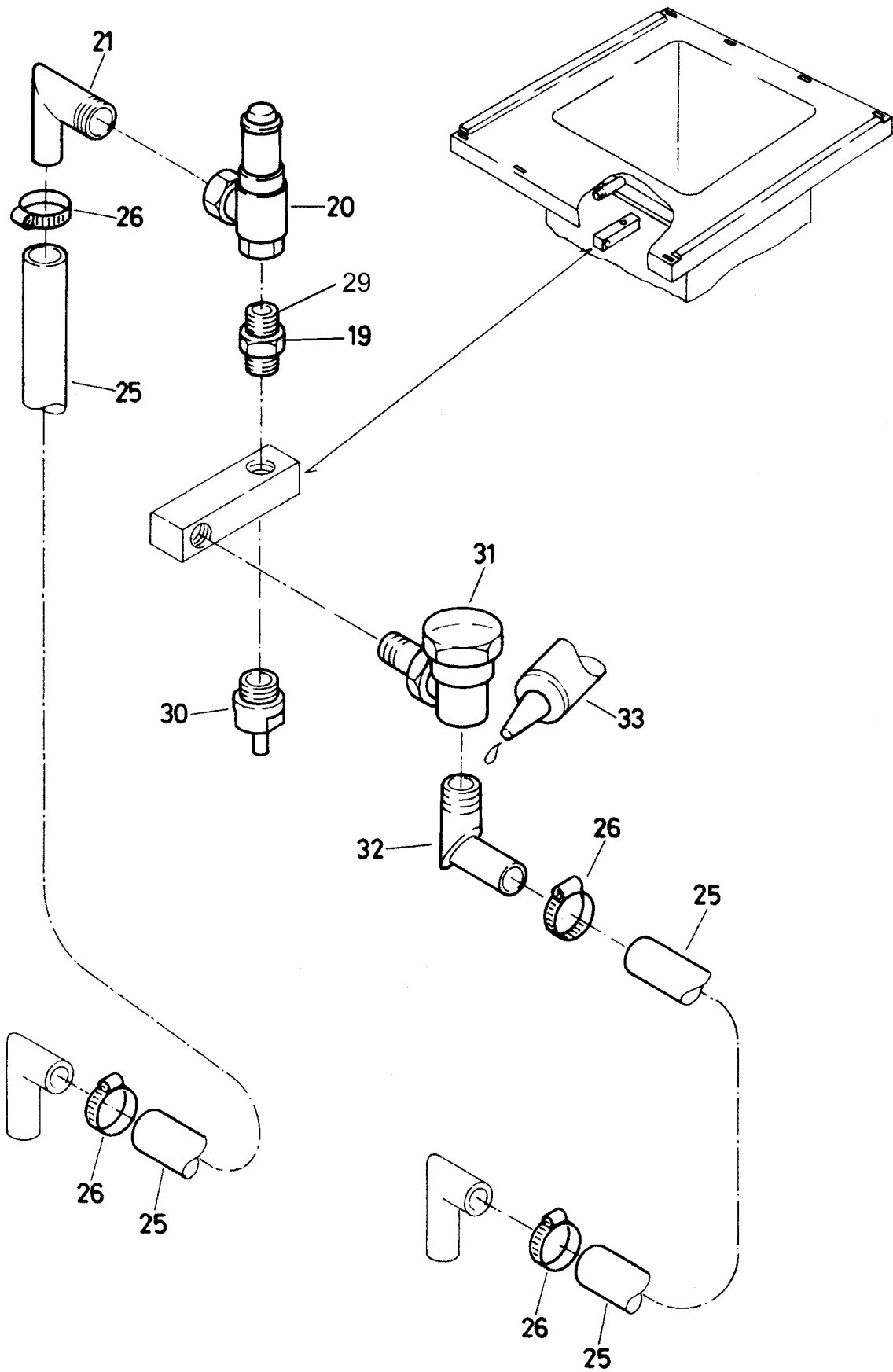

Doc. No.	Index	Issue	DE	FR	IT	GB	Seite/ Page/ Pagina/ Page		
76.9274.19		12/97	Baugruppe	Unité	Unità	Unit	1		
BEN-S (J)PEN-S			Entlüftung	deaération	deaereazione	deaeration			

Pos.	Product No.	Service No.	Bezeichnung	Désignation	Designazione	Designation	Type		Introduction
	76.4440		Entlüftung komplett	deaération complet	deaereazione completo	deaeration complete		1	09/97
19	1117 1192		Verschraubung	vissage	collegamento	screwing		1	12/97
20	75.7000.02	1900 2496	Sicherheitsventil	soupape de sécurité	valvola di sicurezza	safety valve		1	12/97
	76.4462	1900 2496	Sicherheitsventil	soupape de sécurité	valvola di sicurezza	safety valve		1	05/99
21	76.4365		Winkel	angle	angolo	angle		1	12/97
25	1115 1417	1901 6160	Schlauch	tuyau flexible	tubo flessibile	hose		2	12/97
26	1103 1170		Bride	bride	brida	shackle		4	12/97
29	21 775		Teflonband	ruban en téflon	nastro di teflon	teflon band		1	09/00
30	12 7296		Belüfter	aérateur	aereatore	aerator		1	09/97
31	712 344 882	1900 3281	Entlüfter	deaérateur	deaereatore	deaerator	roh	1	09/97
	1201 2065		Entlüfter	deaérateur	deaereatore	deaerator	verchromt	1	09/97
	Spirax 030.150.01		Membran-Element	membrane élément	membrana elemento	membrane element	13°C		
	Spirax 030.150.03		Membran-Element	membrane élément	membrana elemento	membrane element	6°C		
31	712 344 882	1900 3281	Entlüfter	deaérateur	deaereatore	deaerator	verchromt	1	09/97
	1201 2016		Entlüfter	deaérateur	deaereatore	deaerator	roh	1	09/97
32	76.4365		Winkerverschraubung	raccord d'angle vissé	collegamento d'angolo	angular fitting		1	09/97
33	1201 1813		Loctite 577					1	09/97

Pos.	Product No.	Service No.	Bezeichnung	Désignation	Designazione	Designation	Type		Introduction
19	1117 1192		Verschraubung	vissage	collegamento	screwing		1	27. week 2004
20	76.4462	1900 2496	Sicherheitsventil	soupape de sécurité	valvola di sicurezza	safety valve		1	
21	1 102 2414		Winkel	angle	angolo	angle		1	
25	1115 1417	1901 6160	Schlauch	tuyau flexible	tubo flessibile	hose		2	
26	1103 1170		Bride	bride	brida	shackle		6	
29	21 775		Teflonband	ruban en téflon	nastro di teflon	teflon band		1	
30	12 7296		Belüfter	aérateur	aereatore	aerator		1	
31	712 344 882	1900 3281	Entlüfter	deaérateur	deaereatore	deaerator	verchromt	1	
	1201 2016		Entlüfter	deaérateur	deaereatore	deaerator	roh	1	
34	1 102 2435		T-Stück	pièce en T	pezzo a T	T-part		1	
33	1201 1813		Loctite 577					1	09/97

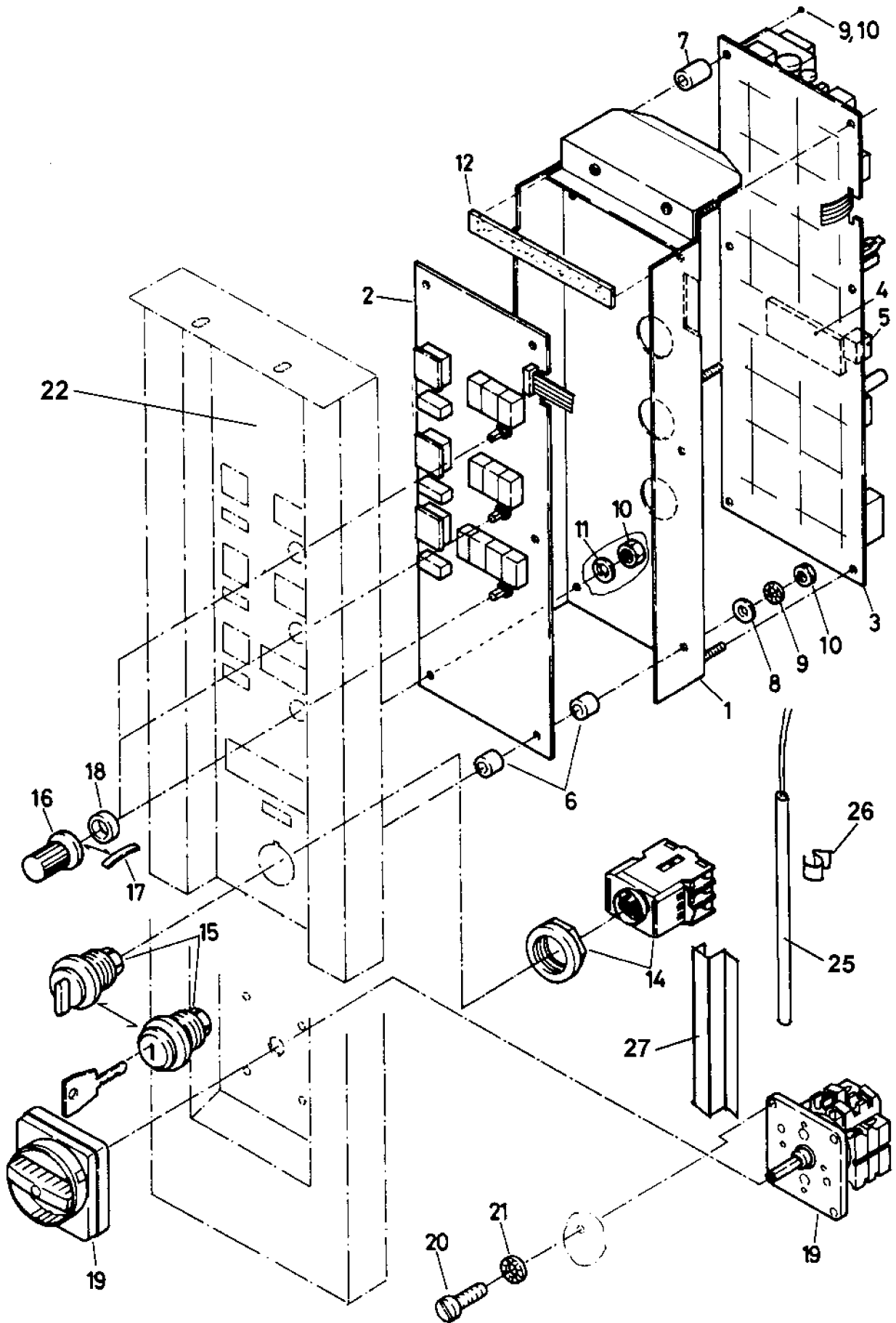

Doc. No.	Index	Issue	DE	FR	IT	GB	Seite/ Page/ Pagina/ Page			
76.9274.22		12/97	Baugruppe	Unité	Unità	Unit	1			
BEN (J)PEN			Schalterfront Steuerung	panneau de commande commande	pannello di comando comando	switch panel control system				

Pos.	Product No.	Service No.	Bezeichnung	Désignation	Designazione	Designation	Type		Introduc-tion
1	76.9039		Blech	tôle	lamiera	sheet		1	12/97
2	76.9110	1802 5566	Bedienungsprint	plaque imprimé/service	print di servizio	operating print	E1	1	12/97
	76.9111	1802 5565	Bedienungsprint	plaque imprimé/service	print di servizio	operating print	E2	1	12/97
3	76.9006	1802 5567	Steuerprint	plaque imprimé/contrôl	print di comando	control circuit board		1	12/97
4	76.9176.02		Processor	processeur	processore	processor		BPTH2.62 BPTH5.06	1 11/99
5	76.9180		Speicher	EEPROM	EEPROM	EEPROM		1	12/97
6	76.3011.01		Distanzhülse	douille de distance	guscio di distanza	spacer sleeve	8mm	12	12/97
7	76.3011.03		Distanzhülse	douille de distance	guscio di distanza	spacer sleeve	12mm	5	12/97
8	1701 3502		Unterlagscheibe	rondelle	rondella	washer	Ø4.3x9	12	12/97
9	1701 7060		Scheibe	disque	disco	disk	M4	12	12/97
10	1701 3004		Mutter	écrou	dado	nut	M4	15	12/97
11	1701 5002		Federring	anneau de ressort	anello di molla	spring ring	M4	1	12/97
12	1201 1522	1101 9072	Dichtung	joint	guarnizione	sealing		1	12/97
14	76.9108.01	1802 5577	Schalter	interrupteur	interruttore	switch		1	12/97
15	76.9075.01	1802 5568	Knopf	bouton	manopola	knob		1	12/97
	76.9075.02		Knopf	bouton	manopola	knob		1	12/97
16	76.9010	1900 6975	Griff	poignée	manetta	knob		3	12/97
17	76.9130	1900 6976	Feder	ressort	molla	spring		3	12/97
18	1201 1910	1900 6977	Dichtung	joint	guarnizione	sealing		3	12/97
16- 18	76.9036	1900 6963	Griff komplett	poignée complet	manetta completo	knob complete		3	12/97
19	76.9164.01	1800 5649	Schalter	interrupteur	interruttore	switch	20A	1	12/97
	76.9164.02	1800 5650	Schalter	interrupteur	interruttore	switch	40A	1	12/97
	76.9164.03	1800 5651	Schalter	interrupteur	interruttore	switch	80A	1	12/97
	76.9164.04		Schalter	interrupteur	interruttore	switch	115A	1	12/97
20	1701 2026		Schraube	vis	vite	screw	M4x20	4	12/97
	1701 2039		Schraube	vis	vite	screw	M5x20	4	12/97
21	1701 7060		Scheibe	disque	disco	disk	M4	4	12/97
	1701 7002		Scheibe	disque	disco	disk	M5	4	12/97

Doc. No.	Index	Issue	DE	FR	IT	GB	Seite/ Page/ Pagina/ Page			
76.9274.22		12/97	Baugruppe	Unité	Unità	Unit	2			
BEN (J)PEN			Schalterfront Steuerung	panneau de commande commande	pannello di comando comando	switch panel control system				

Pos.	Product No.	Service No.	Bezeichnung	Désignation	Designazione	Designation	Type			Introduc- tion
22	76.3020		Folie	pellicule	placca	foil		Therma Comfort	BEN	12/97
	76.3022		Folie	pellicule	placca	foil		Therma Prozess Comfort	BEN	12/97
	76.3116		Folie	pellicule	placca	foil		Therma Prozess Comfort HACCP	BEN-E	09/98
	76.3154		Folie	pellicule	placca	foil		Electrolux Prozess Comfort HACCP	BEN-E	09/00
	76.3117		Folie	pellicule	placca	foil		Therma Prozess Comfort HACCP	BEN-S	09/98
	76.3155		Folie	pellicule	placca	foil		Electrolux Prozess Comfort HACCP	BEN-S	09/00
	76.3721		Folie	pellicule	placca	foil		Electrolux Prozess Comfort HACCP	BEN-S	46.week 2005
	76.3077		Folie Handsteuerung	pellicule commande manuelle	placca regolazione a mano	foil manual control		Therma	BEN	12/97
	76.3156		Folie Handsteuerung	pellicule commande manuelle	placca regolazione a mano	foil manual control		Electrolux	BEN	09/00
	76.3050		Folie	pellicule	placca	foil		Salvis Comfort	BEN	12/97
	76.3051		Folie	pellicule	placca	foil		Salvis Prozess Comfort	BEN	12/97
	76.3120		Folie	pellicule	placca	foil		Salvis Prozess Comfort HACCP	BEN-E	09/98
	76.3214		Folie	pellicule	placca	foil		Salvis instead of 76.3120		04/04
	76.3098		Folie	pellicule	placca	foil		Franke Comfort	BEN	12/97
	76.3099		Folie	pellicule	placca	foil		Franke Prozess Comfort	BEN	12/97
	76.3124		Folie	pellicule	placca	foil		Franke Prozess Comfort HACCP	BEN-E	09/98
	76.3021		Folie	pellicule	placca	foil		Therma Comfort	PEN	12/97
	76.3023		Folie	pellicule	placca	foil		Therma Prozess Comfort	PEN	12/97
	76.3119		Folie	pellicule	placca	foil		Therma Prozess Comfort HACCP	PEN-E	09/98
	76.3158		Folie	pellicule	placca	foil		Electrolux Prozess Comfort HACCP	PEN-E	09.00
	76.3082		Folie	pellicule	placca	foil		Juno Comfort	JPEN	12/97
	76.3083		Folie	pellicule	placca	foil		Juno Prozess Comfort	JPEN	12/97
	76.3127		Folie	pellicule	placca	foil		Juno Prozess Comfort HACCP	JPEN-E	09/98
	76.3171		Folie	pellicule	placca	foil		Junoline Prozess Comfort HACCP	JPEN-E	09.00
25	76.9342		Heizpatrone	résistance de chauffe	resistenza di riscaldamento	heating resistor			1	05/98
26	76.9279	1900 6978	Halter	fixation	sostegno	support			2	05/98
27	76.9336		Haltewinkel	support	supporto	attachement rail			1	05/98

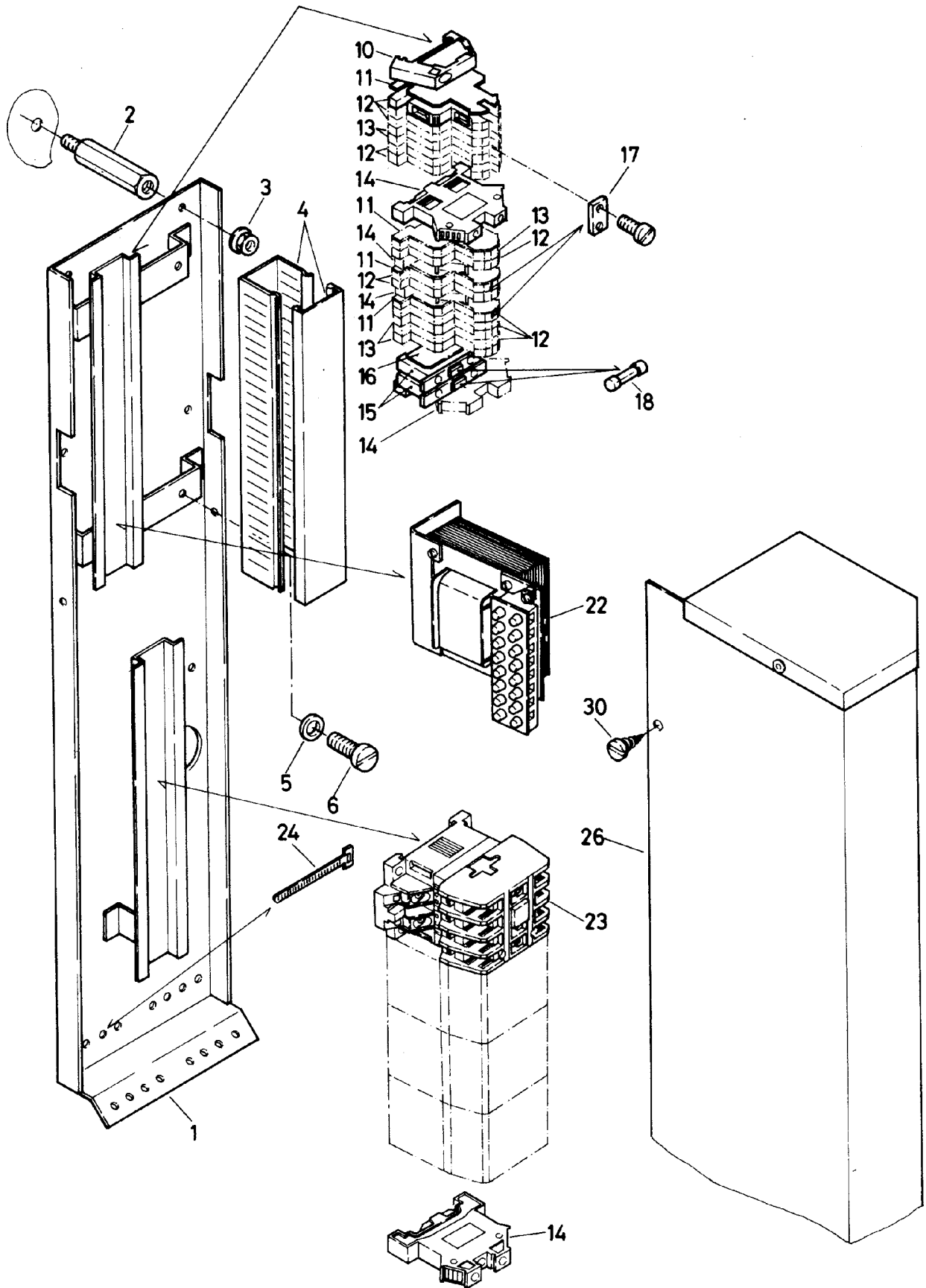

Doc. No.	Index	Issue	DE	FR	IT	GB	Seite/ Page/ Pagina/ Page			
76.9274.30		12/97	Baugruppe	Unité	Unità	Unit	1			
BEN (J)PEN			Klemmen + Schütze	bornes + contacteurs	morse + contattori	terminals + contactors				

Pos.	Product No.	Service No.	Bezeichnung	Désignation	Designazione	Designation	Type	BEN, (J)PEN		Introduction
1	76.2046		Halter	fixation	sostegno	support		E/S/H	1	12/97
2	1201 1945		Halter	fixation	sostegno	support		E/S/H	6	12/97
3	712 044 120.04	1 101 8575	Mutter	écrou	dado	nut	M4	E/S/H	6	12/97
4	74.0216.02		Kanal	conduit	canale	channel		E/S/H	1	12/97
5	1701 3535		Unterlagscheibe	rondelle	rondella	washer	M5	E/S/H	2	12/97
6	10 3179	1101 8605	Schraube	vis	vite	screw	M5x10	E/S/H	2	12/97
10	75.2013		Arretierstück	piece d'arrête	parte d'arresto	stopper part		E S/H	1 3	12/97
11	75.2010.12		Wand	cloison	parete	wall		E/S/H	4	12/97
12	75.2010.10		Klemme	borne	morsa	terminal		E/S/H	11	12/97
13	75.2010.11		Klemme	borne	morsa	terminal		E/S/H	5	12/97
14	75.2011.01		Klemme	borne	morsa	terminal		E/S/H	5	12/97
15	75.2012.01	1802 5573	Klemme	borne	morsa	terminal		E/S/H	2	12/97
16	75.2012.02		Wand	cloison	parete	wall		E/S/H	2	12/97
17	75.2010.14		Verbindung	connexion	congiungimento	connection		E/S/H	3	12/97
18	712 344 362.01	1802 5574	Sicherung	fusible	fusibile	fuse	5x20	E/S/H	2	12/97
22	70.1371	1802 5441	Trafo	transformateur	trasformatore	transformer		E/S/H	1	12/97
23	76.9167.01	1800 5215	Schütz	contacteur	contattore	contactor	K2-12 A10 230V	E	4	12/97
23a	71.3312.01		Relais	relais	relé	relay		S/H	2	12/97
23b	71.3312.03		Sockel	socle	zoccolo	plinth		S/H	2	12/97
24	1115 1391	1101 9008	Kabelbride	bride pour câble	brida di cavo	cable clamp		E/S/H	5	12/97
26	76.9223		Abdeckung	couvercle	copertura	cover		E/S/H	1	12/97
29	712 044 121.01	1900 1235	Mutter	écrou	dado	nut	Ø4.8	E/S/H	2	12/97
30	1701 7535		Schraube	vis	vite	screw	Ø4.8x9.5	E/S/H	2	12/97

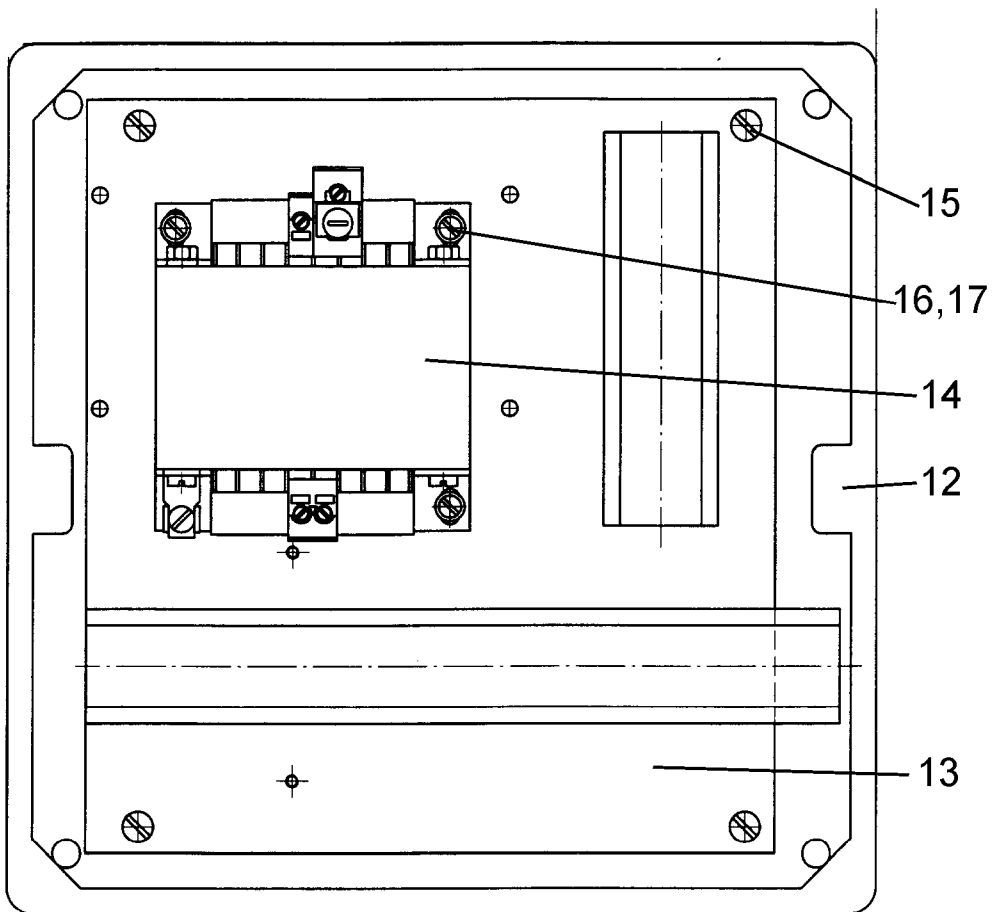
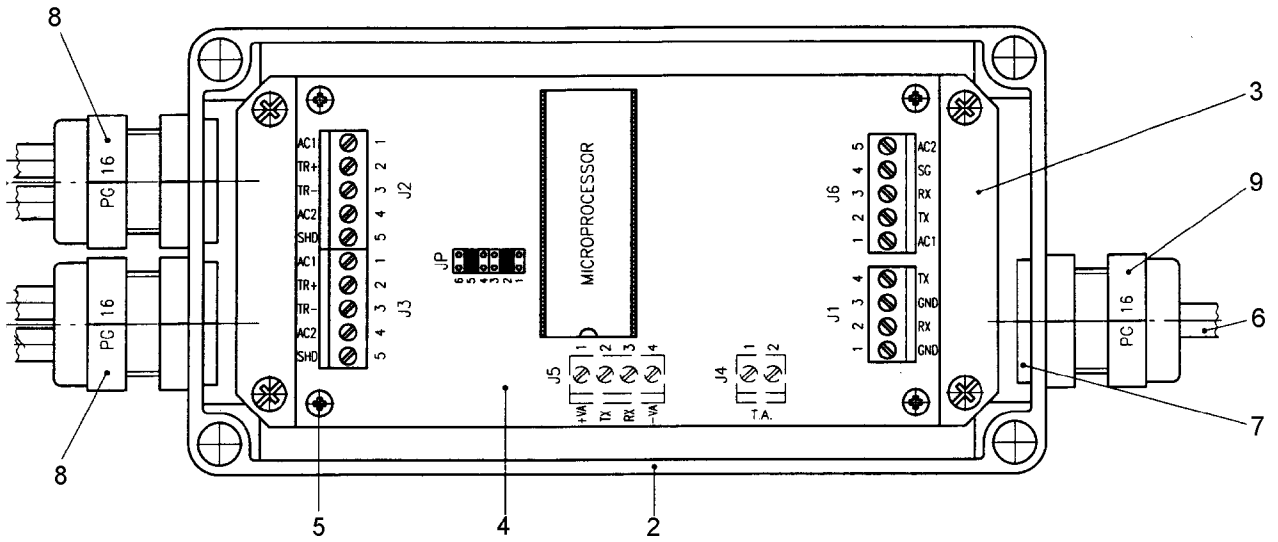

Pos.	Produkt Nr.	Service Nr.	Bezeichnung	désignation	designazione	designation	Type	
			Baugruppe	unité	unità	unit		76.9274.35
			THERMACAM					1
			HACCP Gefährdungsanalyse und kritische Kontrollpunkte		Hazard Analysis and Critical Control Points			09.98
1	76.9301		Interface	interface	interface	interface		1
			komplett	complet	completo	complete		
2	76.9298		Gehäuse	boîtier	base	housing		1
3	76.9299		Platte	plaque	piastra	plate		1
4	76.9302		Interface Print	interface plaque de circuit	interface print	interface board	COP 485.1	1
5	1701 1068		Blechschaube	vis à tôle	vite metallica	sheet screw		4
6	76.9300		Kabel	câble	cavo	cable		1
7	1201 2012		Gegenmutter	contre-écrou	contro dado	counter nut	PG16	3
8	1201 2013		Kabelverschraubung	vissage de câble	collegamento cavo	cable gland	PG16	2
9	1201 2014		Kabelverschraubung	vissage de câble	collegamento cavo	cable gland	PG16	1
11	72.5269		Transformator Einheit	unité d. transformateur	unità d. trasformatore	transformer unit		1
			komplett	complet	completo	complete		
12	75.2008		Gehäuse	boîtier	base	housing		1
13	71.7354		Platte	plaque	piastra	plate		1
14	72.5209		Transformator	transformateur	trasformatore	transformer		1
15	1701 7504		Blechschaube	vis à tôle	vite metallica	sheet screw		4
16	1701 3502		Scheibe	rondelle	disco	washer		4
17	1701 2019		Schraube	vis	vite	screw	M4x8	4
18	1117 1229		Kabelverschraubung	vissage de câble	collegamento cavo	cable gland	PG13.5	2
19	1103 1628		Gegenmutter	contre-écrou	contro dado	counter nut	PG13.5	2

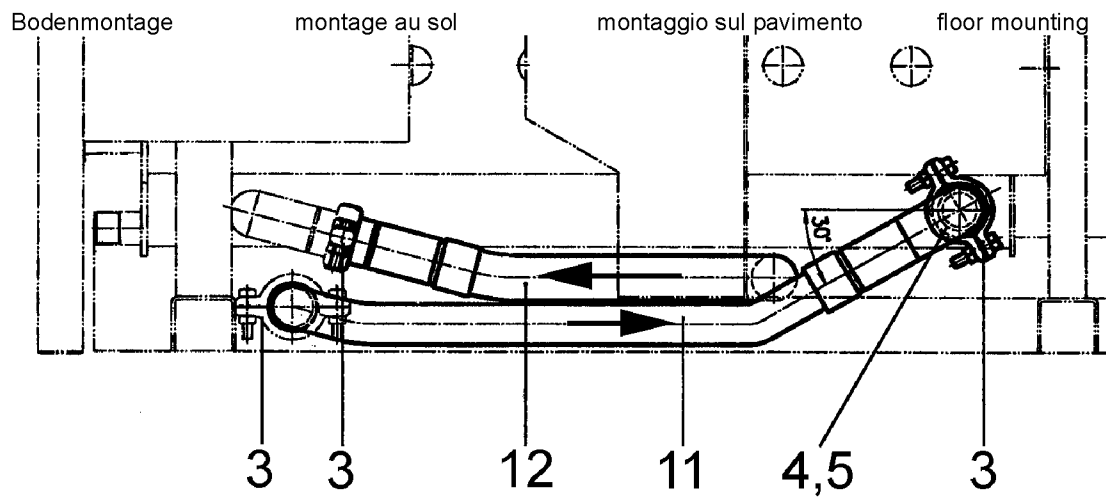
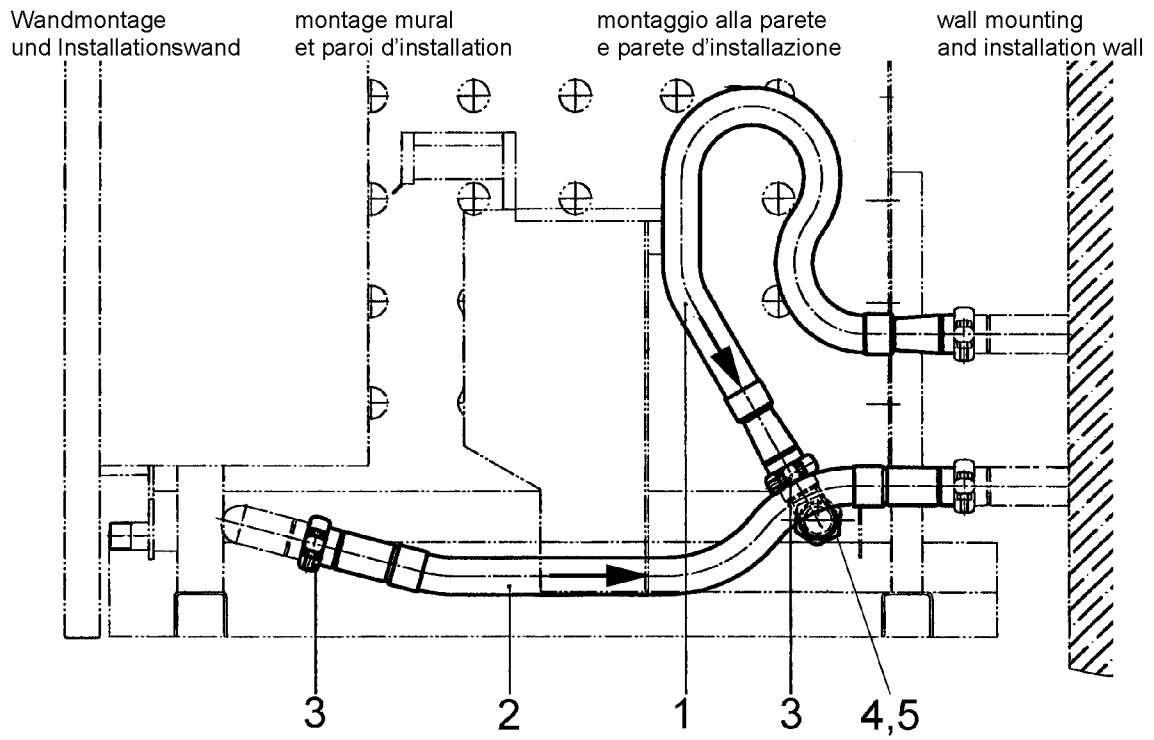

Baugruppe	unité	unità	unit	76.9274.40
Dampfleitung	conduite de vapeur	conduttura di vapore	steam pipe	1
Kondensatleitung	conduite de condensat	conduttura di condensa	condens pipe	12/97

Pos.	Produkt Nr.	Service Nr.	Bezeichnung	désignation	designazione	designation	Modell BEN/PEN				Introd.
							80	150/200	300	400	
			Wandmontage	montage mural	montaggio alla parete	wall mounting					
1	76.2117.02		Leitung	conduite	conduttura	conduit	1	1	1	1	
	76.2117.03		Leitung	conduite	conduttura	conduit	IN	1	1	1	1
2	76.2117.01		Leitung	conduite	conduttura	conduit	1	1	1	1	
	76.2117.02		Leitung	conduite	conduttura	conduit	IN	1	1	1	1
3	76.2030		Klemme	serrage	serrante	clamp	2	2	2	2	
4	1117 1030		Ring	anneau	anello	ring	1	1	1	1	
5	1117 1031		Überwurfmutter	écrou-raccord	dado a risvolto	union nut	1	1	1	1	
		IN =	Installationswand	paroi d'installation	parete d'installazione	installation wall					
			Bodenmontage	montage au sol	montaggio sul pavimento	floor mounting					
11	76.2129		Leitung	conduite	conduttura	conduit	1	1	1	1	
12	76.2117.01		Leitung	conduite	conduttura	conduit	1	1	1	1	
3	76.2030		Klemme	serrage	serrante	clamp	2	2	2	2	
4	1117 1030		Ring	anneau	anello	ring	1	1	1	1	
5	1117 1031		Überwurfmutter	écrou-raccord	dado a risvolto	union nut	1	1	1	1	

Wandmontage
 montage mural
 montaggio alla parete
 wall mounting

und Installationswand
 et paroi d'installation
 e parete d'installazione
 and installation wall

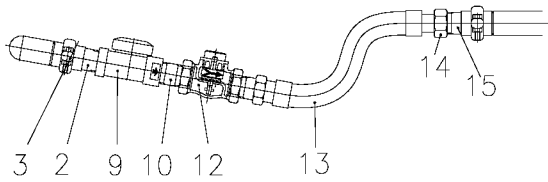
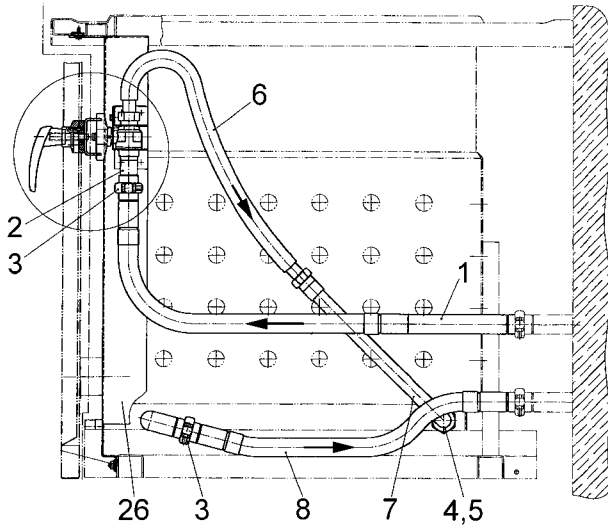

Bodenmontage
 montage au sol
 montaggio sul pavimento
 floor mounting

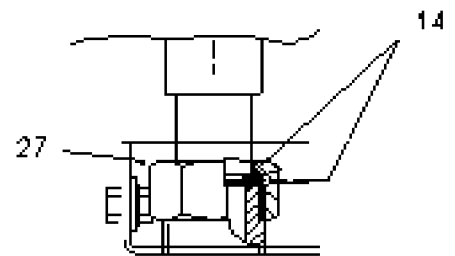
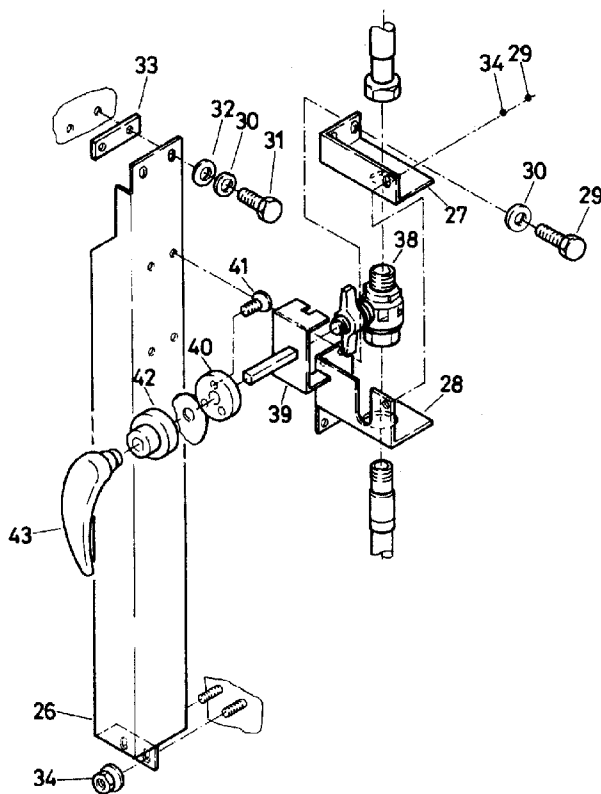
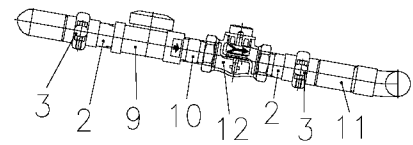
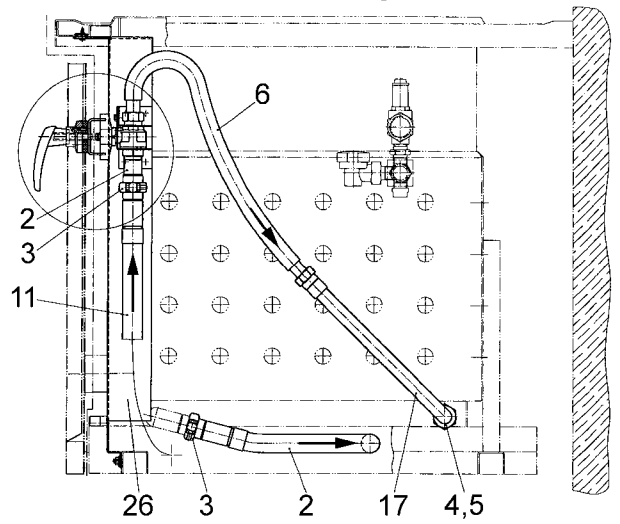

Baugruppe	unité	unità	unit	76.9274.41
Handsteuerung	commande manuelle	regolazione a mano	manual control	
Dampfleitung	conduite de vapeur	conduttura di vapore	steam pipe	1
Kondensatleitung	conduite de condensat	conduttura di condensa	condens pipe	12/97

Pos.	Produkt Nr.	Service Nr.	Bezeichnung	désignation	designazione	designation	Modell BEN/PEN				Introd.
							80	150/200	300	400	
			Wandmontage	montage mural	montaggio alla parete	wall mounting					
1	76.2096.01		Leitung	conduite	conduttura	conduit	1	1	1	1	
	76.2096.02		Leitung	conduite	conduttura	conduit IN	1	1	1	1	
2	76.2098		Zwischenstück	pièce intermédiaire	membro intermedio	partition tube	2	2	2	2	
3	76.2030		Klemme	serrage	serrante	clamp	2	2	2	2	
4	1117 1030		Ring	anneau	anello	ring	1	1	1	1	
5	1117 1031		Überwurfmutter	écrou-raccord	dado a risvolto	union nut	1	1	1	1	
6	70.0411.02		Leitung	conduite	conduttura	conduit	1	1	1	1	
7	76.2709.XX		Leitung	conduite	conduttura	conduit	.01	.02	.03	.04	
8	76.2096.01		Leitung	conduite	conduttura	conduit	1	1	1	1	
	76.2117.02		Leitung	conduite	conduttura	conduit IN	1	1	1	1	
9	1 201 2016		Kondensatableiter	séparateur de condensat	divisore di condensa	steam trap	1	1	1	1	06/03
10	76.4571.01		Doppelnippel	mamelon double	raccordo doppio	double nipple	1	1	1	1	06/03
12	1 201 2035		Rückschlagventil	soupape anti-retour	valvola antiritorno	check valve	1	1	1	1	06/03
13	76.3183.01		Metallschlauch	tuyau métallique	tubo di metallo	metal hose	1	1	1	1	06/03
14	1 101 2086		Dichtung	joint	guarnizione	sealing	3	3	3	3	06/03
15	76.4558.02		Anschluss	raccordement	raccordo	connection	1	1	1	1	06/03
			IN =	Installationswand	paroi d'installation	parete d'installazione	installation wall				
			Bodenmontage	montage au sol	montaggio sul pavimento	floor mounting					
2	76.2098		Zwischenstück	pièce intermédiaire	membro intermedio	partition tube	3	3	3	3	
3	76.2030		Klemme	serrage	serrante	clamp	3	3	3	3	
4	1117 1030		Ring	anneau	anello	ring	1	1	1	1	
5	1117 1031		Überwurfmutter	écrou-raccord	dado a risvolto	union nut	1	1	1	1	
6	70.0411.02		Leitung	conduite	conduttura	conduit	1	1	1	1	
9	1 201 2016		Kondensatableiter	séparateur de condensat	divisore di condensa	steam trap	1	1	1	1	06/03
10	76.4571.01		Doppelnippel	mamelon double	raccordo doppio	double nipple	1	1	1	1	06/03
11	76.2117.01		Leitung	conduite	conduttura	conduit H=700	2	2	2	2	
						conduit H=800	1	1	1	1	
	76.2117.02		Leitung	conduite	conduttura	conduit H=800	1	1	1	1	
12	1 201 2035		Rückschlagventil	soupape anti-retour	valvola antiritorno	check valve	1	1	1	1	06/03
14	1 101 2086		Dichtung	joint	guarnizione	sealing	3	3	3	3	06/03
17	76.2709.XX		Leitung	conduite	conduttura	conduit	.01	.02	.03	.04	
			H	Gerätehöhe	hauteur d'appareil	altezza dell'apparecchio	appliance hight				

Baugruppe	unité	unità	unit	76.9274.41
Handsteuerung	commande manuelle	regolazione a mano	manual control	
Dampfleitung	conduite de vapeur	conduttura di vapore	steam pipe	2
Kondensatleitung	conduite de condensat	conduttura di condensa	condens pipe	12/97

Pos.	Product No.	Service No.	Bezeichnung	Désignation	Designazione	Designation	Type	Introduc- -tion	
26	76.2083.01		Strebe	jambe de force	puntello	strut	H=700	1	12/97
	76.2083.02		Strebe	jambe de force	puntello	strut	H=800	1	12/97
27	76.2084		Halter	fixation	sostegno	support		1	12/97
28	76.2085		Halter	fixation	sostegno	support		1	12/97
29	1701 2509		Schraube	vis	vite	screw	M5x12	5	12/97
30	1701 5004		Federring	anneau de ressort	anello di molla	spring ring	M5	6	12/97
31	1701 2567		Schraube	vis	vite	screw	M5x20	2	12/97
32	1701 3535		Scheibe	disque	disco	disk	M5	2	12/97
33	76.2095		Blech	tôle	lamiera	sheet		4	12/97
34	712 044 120.05	1101 8576	Mutter	écrou	dado	nut	M5	3	12/97
38	76.3079		Ventil	soupape, vanne	valvola	valve	¾"	1	12/97
39	76.2060		Verlängerung	prolongation	allungamento	prolongation		1	12/97
40	76.2070		Ring	anneau	anello	ring		1	12/97
41	1701 1028		Schraube	vis	vite	screw	M4x12	3	12/97
42	76.2059		Rosette	rosace	rosetta	rose		1	12/97
43	71.0268	1900 6126	Hebel	levier	leva	lever		1	12/97

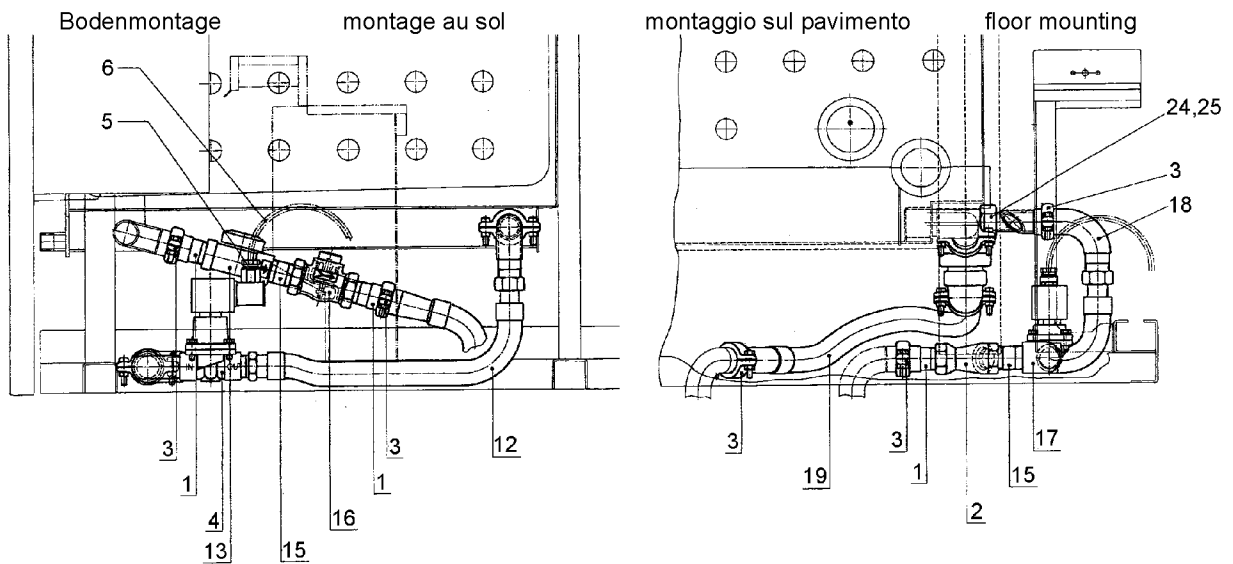
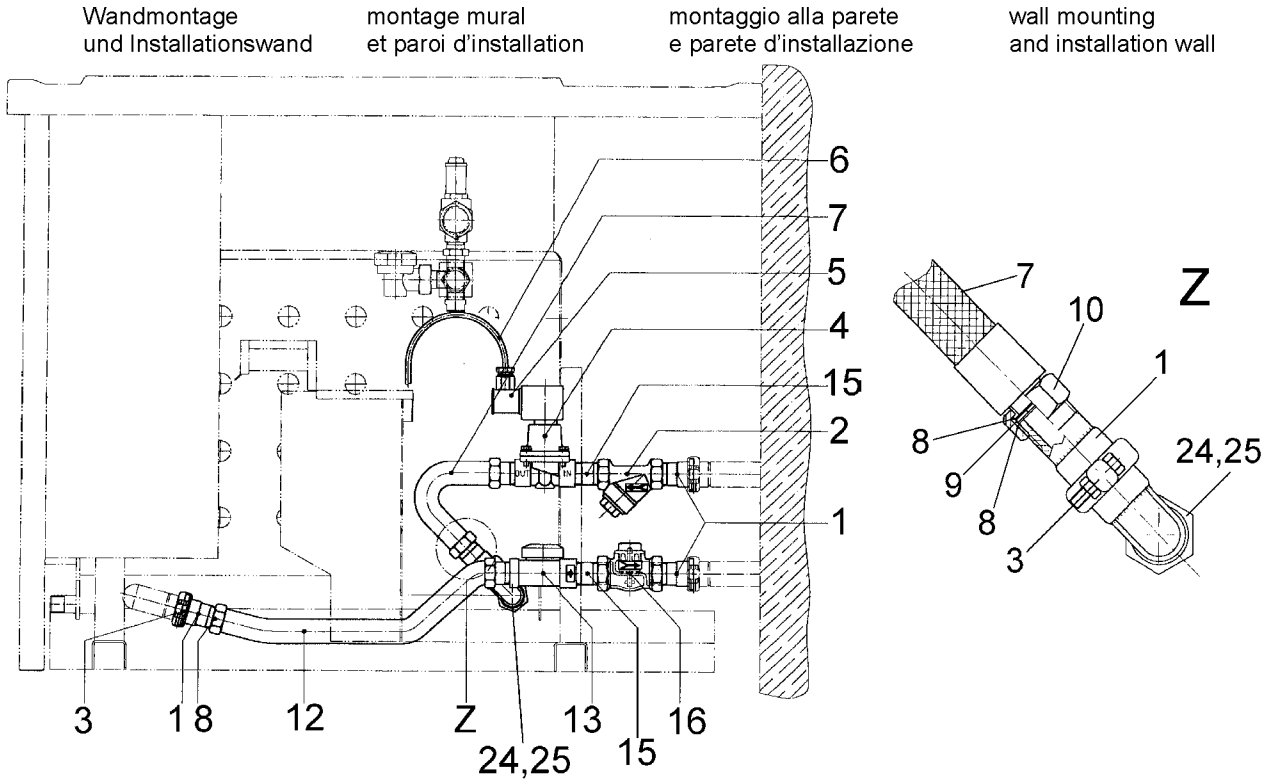

VERSION 2002	Baugruppe	unité	unità	unit	76.9274.42
	Dampfleitung	conduite de vapeur	conduttura di vapore	steam pipe	1
	Kondensatleitung	conduite de condensat	conduttura di condensa	condens pipe	03/02

Pos.	Produkt Nr.	Service Nr.	Bezeichnung	désignation	designazione	designation	Modell BEN/PEN					Introd.
							80	150	200	300	400	
			Wandmontage	montage mural	montaggio alla parete	wall mounting						
1	76.4558.02		Anschlussstück	pièce de raccordement	pezzo di raccordo	connection part	3	3	3	3	3	
2	1201 2036		Schmutzfangsieb	tamis collecteur de saleté	staccio contro la sporcizia	dirt strainer	1	1	1	1	1	
3	76.2030		Klemme	serrage	serrante	clamp	2	2	2	2	2	
4	76.3097		Magnetventil	vanne magnétique	elettrovalvola	solenoid valve	1	1	1	1	1	
5	76.4935		Stecker	fiche	spina	plug	1	1	1	1	1	
6	76.9064.04		Kabel	câble	cavo	cable	1	1	1	1	1	
7	76.3183.03		Leitung	conduite	conduttura	conduit	1	1	1	1	1	
8	1101 2086		Dichtungsring	joint d'étanchéité	anello di guarnizione	washer	3	3	3	3	3	
9	76.4552.XX		Drosselblende	tuyère	ugello	orifice	.03	.05	.06	.07	.08	
10	1201 1813		Loctite 577									
12	76.3183.01		Leitung	conduite	conduttura	conduit	1	1	1	1	1	
13	1201 2016		Kondensatabscheider	séparateur de condensat	divisore di condensa	steam trap	1	1	1	1	1	
15	76.4571.01		Anschlussstück	pièce de raccordement	pezzo di raccordo	connection part	2	2	2	2	2	
	76.4571.02		Anschlussstück	pièce de raccordement	pezzo di raccordo	connection part	IN	2	2	2	2	
16	1201 2035		Rückschlagventil	soupape anti-retour	valvola antiritorno	check valve	1	1	1	1	1	
24	1117 1030		Ring	anneau	anello	ring	1	1	1	1	1	
25	1117 1031		Überwurfmutter	écrou-raccord	dado a risvolto	union nut	1	1	1	1	1	
		IN =	Installationswand	paroi d'installation	parete d'installazione	installation wall						
			Bodenmontage	montage au sol	montaggio sul pavimento	floor mounting						
1	76.4558.02		Anschlussstück	pièce de raccordement	pezzo di raccordo	connection part	3	3	3	3	3	
2	1201 2036		Schmutzfangsieb	tamis collecteur de saleté	staccio contro la sporcizia	dirt strainer	1	1	1	1	1	
3	76.2030		Klemme	serrage	serrante	clamp	5	5	5	5	5	
4	76.3097		Magnetventil	vanne magnétique	elettrovalvola	solenoid valve	1	1	1	1	1	
5	76.4935		Stecker	fiche	spina	plug	1	1	1	1	1	
6	76.9064.04		Kabel	câble	cavo	cable	1	1	1	1	1	
10	1201 1813		Loctite 577									
12	76.3183.01		Leitung	conduite	conduttura	conduit	1	1	1	1	1	
13	1201 2016		Kondensatabscheider	séparateur de condensat	divisore di condensa	steam trap	1	1	1	1	1	
15	76.4571.01		Anschlussstück	pièce de raccordement	pezzo di raccordo	connection part	2	2	2	2	2	
16	1201 2035		Rückschlagventil	soupape anti-retour	valvola antiritorno	check valve	1	1	1	1	1	
17	1201 2009		Bogen	arc	arco	bow	1	1	1	1	1	
18	76.4558.01		Anschlussstück	pièce de raccordement	pezzo di raccordo	connection part	1	1	1	1	1	
19	76.2117.01		Leitung	conduite	conduttura	conduit	1	1	1	1	1	
24	1117 1030		Ring	anneau	anello	ring	1	1	1	1	1	
25	1117 1031		Überwurfmutter	écrou-raccord	dado a risvolto	union nut	1	1	1	1	1	

Heisswasserleitung conduite d'eau chaude condotta acqua calda hot water pipe
 "AUDI"

Elektronische Steuerung commande électronique comando elettronico electronic control
 Montage Installationswand montage paroi d'installation montaggio parete d'installazione installation wall

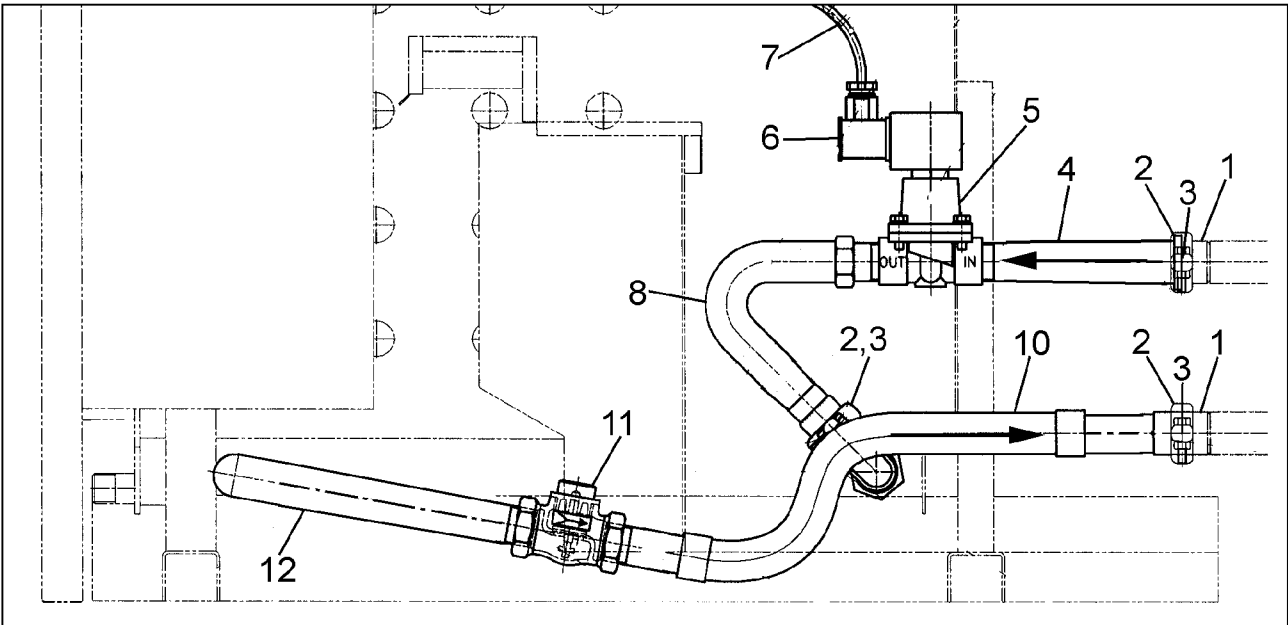

Hand Steuerung commande manuelle comando a mano manual control
 Montage Installationswand montage paroi d'installation montaggio parete d'installazione installation wall

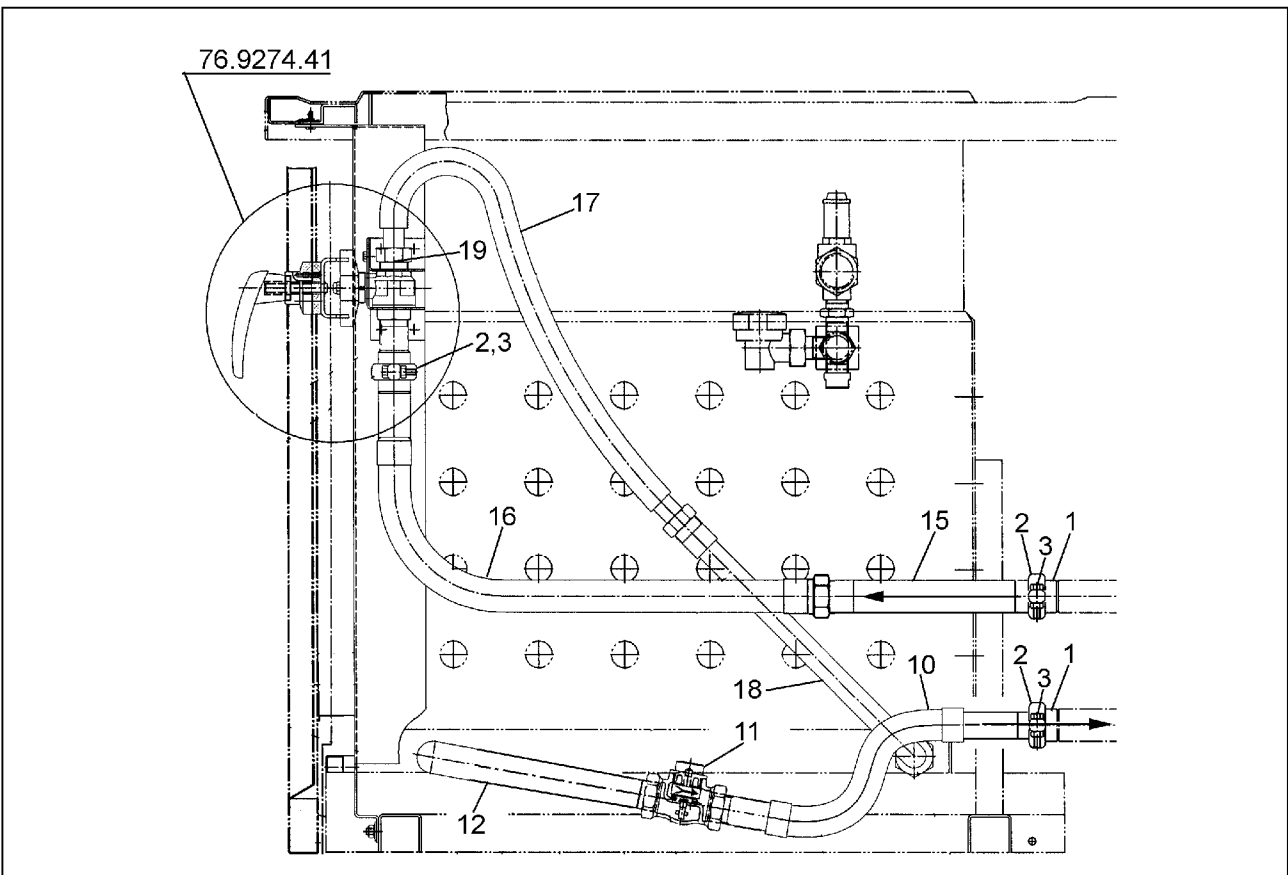

AUDI	Baugruppe Heisswasserleitung	unité conduite d'eau chaude	unità conduttura acqua calda	unit hot water pipe	76.9274.47 1 06/04
-------------	---------------------------------	--------------------------------	---------------------------------	------------------------	--------------------------

Pos.	Produkt Nr.	Service Nr.	Bezeichnung	désignation	designazione	designation	Modell BEN/PEN					Introd.
							80	150	200	300	400	
Elektronische Steuerung commande électronique comando elettronico electronic control												
1	76.5689		Stutzen	manchon	carabina	flange	3	3	3	3	3	
2	76.2030		Klemmbügel	étrier de serrage	archetto serrante	clamp strap	3	3	3	3	3	
3	1101 2177		Dichtung	joint	guarnizione	sealing	3	3	3	3	3	
4	76.5690.01		Schlauch	tuyau flexible	tubo flessibile	hose	1	1	1	1	1	
5	76.3217		Magnetventil NW25	vanne magnétique	elettrovalvola	solenoid valve	1	1	1	1	1	
6	76.4935		Stecker	fiche	spina	plug	1	1	1	1	1	
7	76.9064.04		Kabel	câble	cavo	cable	1	1	1	1	1	
8	76.5690.02		Schlauch	tuyau flexible	tubo flessibile	hose	1	1	1	1	1	
10	76.5690.04		Schlauch	tuyau flexible	tubo flessibile	hose	1	1	1	1	1	
11	76.3218		Rückschlagventil	soupape anti-retour	valvola antiritorno	check valve	1	1	1	1	1	
12	76.2325.01		Rohrleitung	tuyauterie	tubo conduttore	pipe			1			
	76.2325.02		Rohrleitung	tuyauterie	tubo conduttore	pipe				1		
	76.2325.03		Rohrleitung	tuyauterie	tubo conduttore	pipe					1	
	1201 1813		Loctite 577				x	x	x	x	x	
Handsteuerung commande manuelle regolazione a mano manual control												
1	76.5689		Stutzen	manchon	carabina	flange	3	3	3	3	3	
2	76.2030		Klemmbügel	étrier de serrage	archetto serrante	clamp strap	3	3	3	3	3	
3	1101 2177		Dichtung	joint	guarnizione	sealing	3	3	3	3	3	
15	76.2326.01		Rohrleitung	tuyauterie	tubo conduttore	pipe	1	1	1	1	1	
16	76.5690.04		Schlauch	tuyau flexible	tubo flessibile	hose	1	1	1	1	1	
17	76.3183.07		Schlauch	tuyau flexible	tubo flessibile	hose	1	1	1	1	1	
18	76.2326.02		Rohrleitung	tuyauterie	tubo conduttore	pipe	1	1	1	1	1	
19	1101 2035		Dichtung	joint	guarnizione	sealing	1	1	1	1	1	
10	76.5690.04		Schlauch	tuyau flexible	tubo flessibile	hose	1	1	1	1	1	
11	76.3218		Rückschlagventil	soupape anti-retour	valvola antiritorno	check valve	1	1	1	1	1	
12	76.2325.01		Rohrleitung	tuyauterie	tubo conduttore	pipe			1			
	76.2325.02		Rohrleitung	tuyauterie	tubo conduttore	pipe				1		
	76.2325.03		Rohrleitung	tuyauterie	tubo conduttore	pipe					1	
	1201 1813		Loctite 577				x	x	x	x	x	

Heisswasserleitung conduite d'eau chaude condotta acqua calda hot water pipe
BEN-H

Hand Steuerung
 Montage Installationswand

commande manuelle
 montage paroi d'installation

comando a mano
 montaggio parete d'installazione

manual control
 installation wall

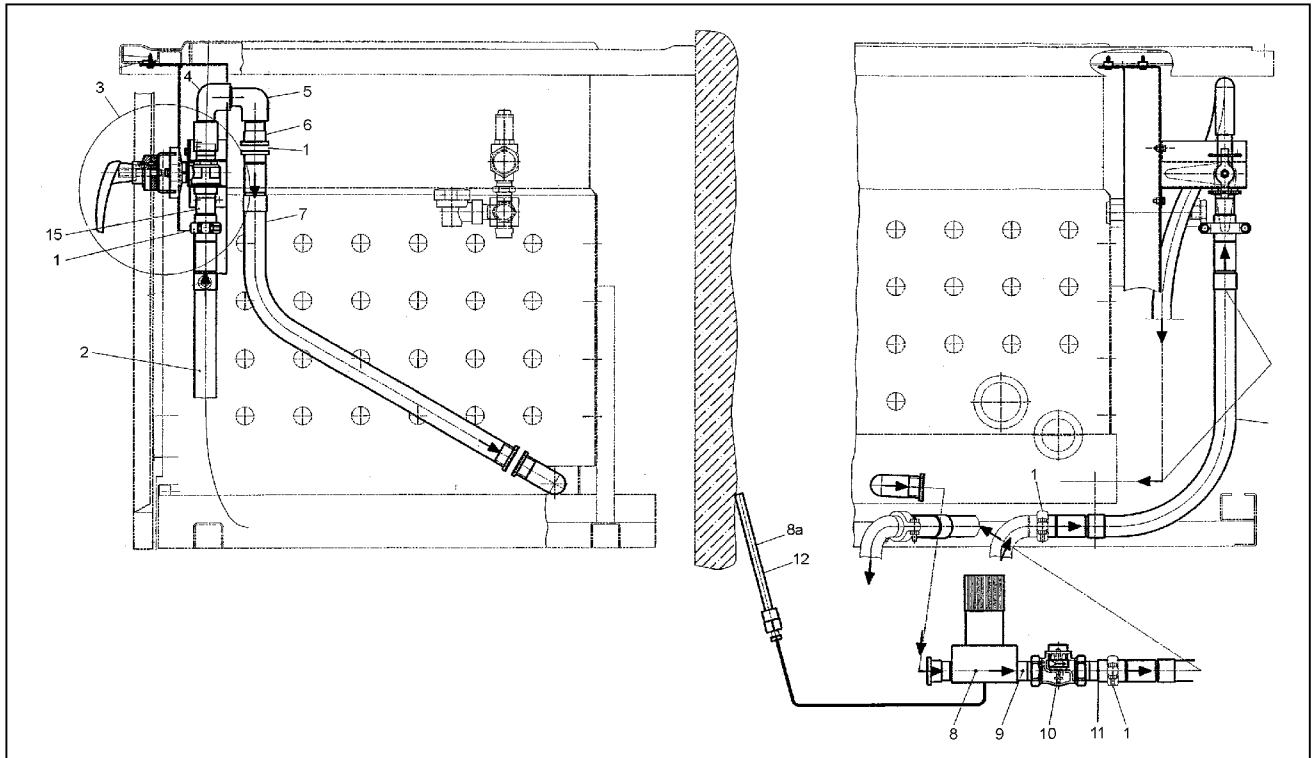

Doc. No.	Index	Issue	DE	FR	IT	GB	Seite/ Page/ Pagina/ Page				
76.9274.48		11/05	Baugruppe	Unité	Unità	Unit	1				
BEN-H			Heisswasserleitung Vorlauf/Rücklauf	Conduites d'eau chaude entrée/reflux	Condutture acqua calda entrata/riflusso	Hotwater pipes entrance/return flow					

Pos.	Product No.	Service No.	Bezeichnung	Désignation	Designazione	Designation	Type	80	150	200	300	400			Introduc.
1	76.2030		Kupplung Sandvik	accouplement	agganciamento	coupling Sandvik		5	5	5	5	5			
1a	76.3248		Dichtung	joint	guarnizione	sealing	PTFE	5	5	5	5	5			
2	76.2117.02		Schlauch	tuyau flexible	tubo flessibile	hose		1	1	1	1	1			
3			Siehe Kapitel 76.9274.41	voir chapitre 76. 9274.41	vedere capitolo 76. 9274.41	see chapter 76. 9274.41		1	1	1	1	1			
4	1201 2009		Kniestück	coude	gomito	angle		1	1	1	1	1			
5	1201 2009		Kniestück	coude	gomito	angle		1	1	1	1	1			
6	76.4558.02		Flansch	bride	flangia	flange		1	1	1	1	1			
7	76.3336		Schlauch	tuyau flexible	tubo flessibile	hose		2	2	2	2	2			
8	1105 1278		Temperaturregler Einstellung auf Nummer 5	régulateur de temp. ajustage sur numéro 5	regolatore di temp. aggiustamento su numero 5	temperature regulator adjustment to number 5	AVTB20	1	1	1	1	1			
8a			Fühlerrohr	tuyau de sonde	tubo del sensore	sensor tube		1	1	1	1	1			
9	76.4571.03		Nippel	mamelon	raccordo	nipple		1	1	1	1	1			
10	1201 2035		Rückschlagventil	soupape anti-retour	valvola ritegno	check valve		1	1	1	1	1			
11	76.2098		Flansch	bride	flangia	flange		1	1	1	1	1			
12	1201 1510		Wärmeleitpaste	pâte conduction thermique	paste conduzione di calore	heat-conductive paste		X	X	X	X	X			
15	76.2098		Stutzen	manchon	carabina	flange		1	1	1	1	1			

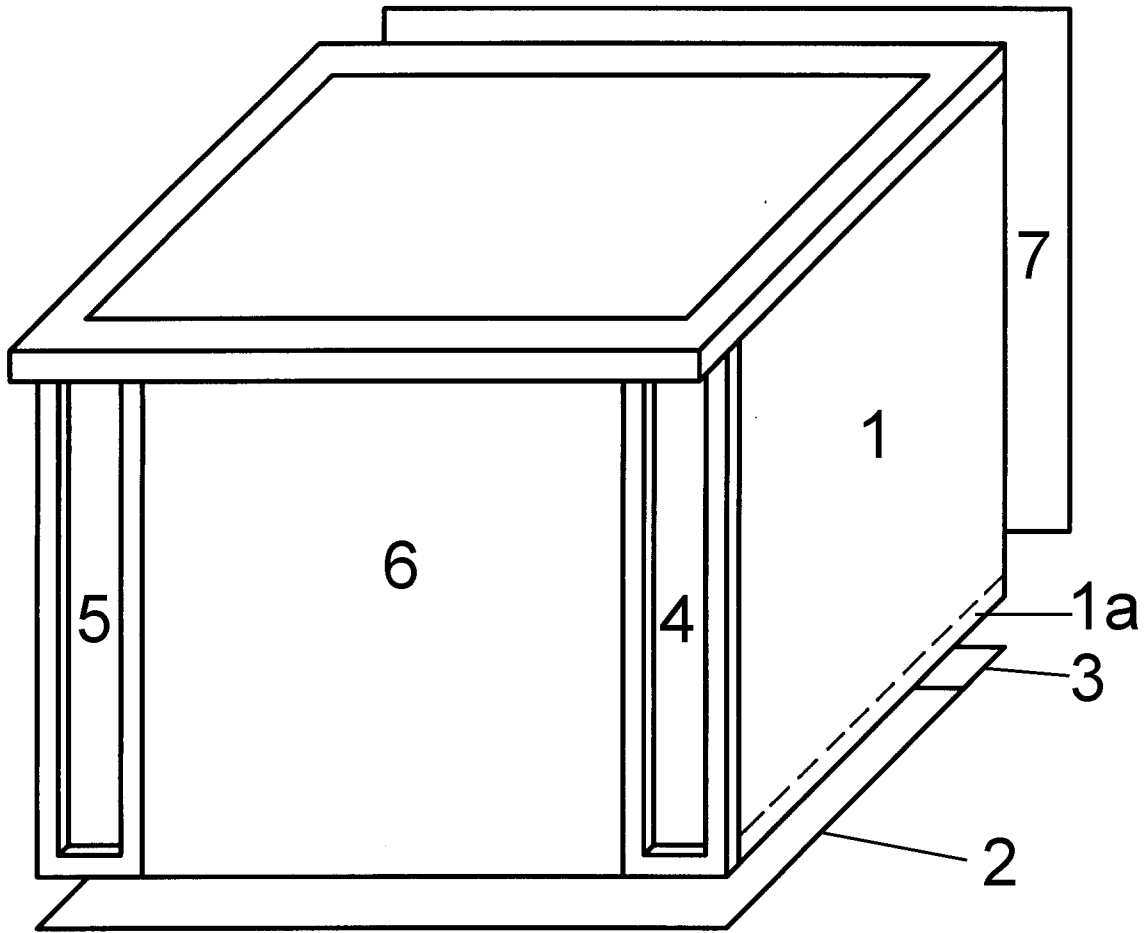

Doc. No.	Index	Issue	DE	FR	IT	GB	Seite/ Page/ Pagina/ Page			
76.9274.50		12/97	Baugruppe	Unité	Unità	Unit	1			
			Verschalung	revêtement	rivestimento	paneling				

Pos.	Product No.		Bezeichnung	Désignation	Designazione	Designation	BON/BEN/(J)PEN								Introdu- c-tion
							40	60	80	100	150	200	300	400	
1	76.5073.01	W/700h/800/L	Seitenwand	paroi latérale	parete laterale	side panel	1	1	1	1	1	1	1	1	12/97
	76.5073.11	W/700h/800/R	Seitenwand	paroi latérale	parete laterale	side panel	1	1	1	1	1	1	1	1	12/97
	76.5073.03	W/700h/900/L	Seitenwand	paroi latérale	parete laterale	side panel	1	1	1	1	1	1	1	1	12/97
	76.5073.13	W/700h/900/R	Seitenwand	paroi latérale	parete laterale	side panel	1	1	1	1	1	1	1	1	12/97
	76.5139.01	F/700h/800/L	Seitenwand	paroi latérale	parete laterale	side panel	1	1	1	1	1	1	1	1	12/97
	76.5139.01	F/700h/800/R	Seitenwand	paroi latérale	parete laterale	side panel	1	1	1	1	1	1	1	1	12/97
	76.5139.03	F/700h/900/L	Seitenwand	paroi latérale	parete laterale	side panel	1	1	1	1	1	1	1	1	12/97
	76.5139.03	F/700h/900/R	Seitenwand	paroi latérale	parete laterale	side panel	1	1	1	1	1	1	1	1	12/97
	76.5395.01	Ju/W/650h/850/L	Seitenwand	paroi latérale	parete laterale	side panel			1		1				12/97
	76.5396.01	Ju/W/650h/850/R	Seitenwand	paroi latérale	parete laterale	side panel			1		1				12/97
	76.5395.01	Ju/W/650h/900/L	Seitenwand	paroi latérale	parete laterale	side panel			1		1				12/97
	76.5396.01	Ju/W/650h/900/R	Seitenwand	paroi latérale	parete laterale	side panel			1		1				12/97
	76.5395.02	Ju/W/700h/850/L	Seitenwand	paroi latérale	parete laterale	side panel						1	1		12/97
	76.5396.02	Ju/W/700h/850/R	Seitenwand	paroi latérale	parete laterale	side panel						1	1		12/97
	76.5395.02	Ju/W/700h/900/L	Seitenwand	paroi latérale	parete laterale	side panel						1	1		12/97
	76.5396.02	Ju/W/700h/900/R	Seitenwand	paroi latérale	parete laterale	side panel						1	1		12/97
	76.5073.02	S/N/800h/800/L	Seitenwand	paroi latérale	parete laterale	side panel	1	1	1	1	1	1	1	1	12/97
	76.5073.12	S/N/800h/800/R	Seitenwand	paroi latérale	parete laterale	side panel	1	1	1	1	1	1	1	1	12/97
	76.5073.04	S/N/800h/900/L	Seitenwand	paroi latérale	parete laterale	side panel	1	1	1	1	1	1	1	1	12/97
	76.5073.14	S/N/800h/900/R	Seitenwand	paroi latérale	parete laterale	side panel	1	1	1	1	1	1	1	1	12/97
	76.5139.02	S/F/800h/800/L	Seitenwand	paroi latérale	parete laterale	side panel	1	1	1	1	1	1	1	1	12/97
	76.5139.02	S/F/800h/800/R	Seitenwand	paroi latérale	parete laterale	side panel	1	1	1	1	1	1	1	1	12/97
	76.5139.04	S/F/800h/900/L	Seitenwand	paroi latérale	parete laterale	side panel	1	1	1	1	1	1	1	1	12/97
	76.5139.04	S/F/800h/900/R	Seitenwand	paroi latérale	parete laterale	side panel	1	1	1	1	1	1	1	1	12/97
	76.5290.03	Ju/S/750h/850/L	Seitenwand	paroi latérale	parete laterale	side panel			1		1	1	1		12/97
	76.5308.03	Ju/S/750h/850/R	Seitenwand	paroi latérale	parete laterale	side panel			1		1	1	1		12/97
	76.5290.03	Ju/S/750h/900/L	Seitenwand	paroi latérale	parete laterale	side panel			1		1	1	1		12/97
	76.5308.03	Ju/S/750h/900/R	Seitenwand	paroi latérale	parete laterale	side panel			1		1	1	1		12/97

Doc. No.	Index	Issue	DE	FR	IT	GB	Seite/ Page/ Pagina/ Page						
76.9274.50		12/97	Baugruppe	Unité	Unità	Unit	2						
			Verschalung	revêtement	rivestimento	paneling							

Pos.	Product No.		Bezeichnung	Désignation	Designazione	Designation	BON/BEN/(J)PEN							Introduc	
							40	60	80	100	150	200	300		400
1	76.5476.01	Ju/S/F/650h/900/L	Seitenwand	paroi latérale	parete laterale	side panel	1	1	1	1	1	1	1	1	08/99
	76.5476.02	Ju/S/F/700h/900/L	Seitenwand	paroi latérale	parete laterale	side panel	1	1	1	1	1	1	1	1	08/99
	76.5476.03	Ju/S/F/750h/900/L	Seitenwand	paroi latérale	parete laterale	side panel	1	1	1	1	1	1	1	1	08/99
	76.5477.01	Ju/S/F/650h/900/R	Seitenwand	paroi latérale	parete laterale	side panel	1	1	1	1	1	1	1	1	08/99
	76.5477.02	Ju/S/F/700h/900/R	Seitenwand	paroi latérale	parete laterale	side panel	1	1	1	1	1	1	1	1	08/99
	76.5477.03	Ju/S/F/750h/900/R	Seitenwand	paroi latérale	parete laterale	side panel	1	1	1	1	1	1	1	1	08/99
	76.5478.01	Ju/S/NA/650h/900/L	Seitenwand	paroi latérale	parete laterale	side panel	1	1	1	1	1	1	1	1	08/99
	76.5478.02	Ju/S/NA/700h/900/L	Seitenwand	paroi latérale	parete laterale	side panel	1	1	1	1	1	1	1	1	08/99
	76.5478.03	Ju/S/NA/750h/900/L	Seitenwand	paroi latérale	parete laterale	side panel	1	1	1	1	1	1	1	1	08/99
	76.5479.01	Ju/S/NA/650h/900/R	Seitenwand	paroi latérale	parete laterale	side panel	1	1	1	1	1	1	1	1	08/99
	76.5479.02	Ju/S/NA/700h/900/R	Seitenwand	paroi latérale	parete laterale	side panel	1	1	1	1	1	1	1	1	08/99
	76.5479.03	Ju/S/NA/750h/900/R	Seitenwand	paroi latérale	parete laterale	side panel	1	1	1	1	1	1	1	1	08/99
1a	76.5187.01	W/700h/800/L/R 2G/oW	Blende	bandeau	copertura	filler	1	1	1	1	1	1	1	1	12/97
	76.5187.02	W/700h/900/L/R 2G/oW	Blende	bandeau	copertura	filler	1	1	1	1	1	1	1	1	12/97
	76.5186.01	F/700h/800/L/R 2G/oW	Blende	bandeau	copertura	filler	1	1	1	1	1	1	1	1	12/97
	76.5186.02	F/700h/900/L/R 2G/oW	Blende	bandeau	copertura	filler	1	1	1	1	1	1	1	1	12/97
	76.5187.01	S/N/800h/800/L/R 2G/oW	Blende	bandeau	copertura	filler	1	1	1	1	1	1	1	1	12/97
	76.5187.02	S/N/800h/900/L/R 2G/oW	Blende	bandeau	copertura	filler	1	1	1	1	1	1	1	1	12/97
	76.5186.01	S/F/800h/800/L/R 2G/oW	Blende	bandeau	copertura	filler	1	1	1	1	1	1	1	1	12/97
	76.5187.02	S/F/800h/900/L/R 2G/oW	Blende	bandeau	copertura	filler	1	1	1	1	1	1	1	1	12/97

Doc. No.	Index	Issue	DE	FR	IT	GB	Seite/ Page/ Pagina/ Page					
76.9274.50		12/97	Baugruppe	Unité	Unità	Unit	3					
			Verschalung	revêtement	rivestimento	paneling						

Pos.	Product No.		Bezeichnung	Désignation	Designazione	Designation	BON/BEN/(J)PEN								Introdu.
							40	60	80	100	150	200	300	400	
2	76.5192.01	W	Boden	fond	fondo	base	BON								12/97
	76.5185.01	W	Boden	fond	fondo	base		BON							12/97
	76.5285.01	W	Boden	fond	fondo	base			BON	BON					12/97
	76.5207.01	W	Boden	fond	fondo	base					BON				12/97
	76.5197.01	(Ju)W	Boden	fond	fondo	base			BEN PEN						12/97
	76.5212.01	(Ju)W	Boden	fond	fondo	base					BEN PEN	BEN PEN			12/97
	76.5213.01	(Ju)W	Boden	fond	fondo	base							BEN PEN		12/97
	76.5222.01	W	Boden	fond	fondo	base								BEN	12/97
	76.5192.02	S	Boden	fond	fondo	base	BON								12/97
	76.5185.02	S	Boden	fond	fondo	base		BON							12/97
	76.5285.02	S	Boden	fond	fondo	base			BON	BON					12/97
	76.5207.02	S	Boden	fond	fondo	base					BON				12/97
	76.5197.02	(Ju)S	Boden	fond	fondo	base			BEN PEN						12/97
	76.5212.02	(Ju)S	Boden	fond	fondo	base					BEN PEN	BEN PEN			12/97
	76.5213.02	(Ju)S	Boden	fond	fondo	base							BEN PEN		12/97
	76.5222.02	S	Boden	fond	fondo	base								BEN	12/97
	76.5192.04	S/F/800	Boden	fond	fondo	base	BON								12/97
	76.5185.04	S/F/800	Boden	fond	fondo	base		BON							12/97
	76.5285.04	S/F/800	Boden	fond	fondo	base			BON	BON					12/97
	76.5207.04	S/F/800	Boden	fond	fondo	base					BON				12/97
	76.5197.04	(Ju) S/F/800	Boden	fond	fondo	base			BEN PEN						12/97
	76.5212.04	(Ju) S/F/800	Boden	fond	fondo	base					BEN PEN	BEN PEN			12/97
	76.5213.04	(Ju) S/F/800	Boden	fond	fondo	base							BEN PEN		12/97
	76.5222.04	S/F/800	Boden	fond	fondo	base								BEN	12/97
	76.5192.03	S/Hy/800	Boden	fond	fondo	base	BON								12/97
	76.5185.03	S/Hy/800	Boden	fond	fondo	base		BON							12/97
	76.5285.03	S/Hy/800	Boden	fond	fondo	base			BON	BON					12/97
	76.5207.03	S/Hy/800	Boden	fond	fondo	base					BON				12/97

Doc. No.	Index	Issue	DE	FR	IT	GB	Seite/ Page/ Pagina/ Page					
76.9274.50		12/97	Baugruppe	Unité	Unità	Unit	4					
			Verschalung	revêtement	rivestimento	paneling						

Pos.	Product No.		Bezeichnung	Désignation	Designatione	Designation	BON/BEN/(J)PEN								Intro- duction
							40	60	80	100	150	200	300	400	
2	76.5197.03	(Ju) S/ Hy /800	Boden	fond	fondo	base			BEN PEN						12/97
	76.5212.03	(Ju) S/ Hy /800	Boden	fond	fondo	base				BEN PEN	BEN PEN				12/97
	76.5213.03	(Ju) S/ Hy /800	Boden	fond	fondo	base						BEN PEN			12/97
	76.5222.05	S/ Hy /900	Boden	fond	fondo	base							BEN		12/97
	76.5192.05	S/Hy/900	Boden	fond	fondo	base	BON								12/97
	76.5185.05	S/Hy/900	Boden	fond	fondo	base		BON							12/97
	76.5285.05	S/Hy/900	Boden	fond	fondo	base			BON	BON					12/97
	76.5207.05	S/Hy/900	Boden	fond	fondo	base				BON					12/97
	76.5197.05	(Ju) S/ Hy /900	Boden	fond	fondo	base			BEN PEN						12/97
	76.5212.05	(Ju) S/ Hy /900	Boden	fond	fondo	base				BEN PEN	BEN PEN				12/97
	76.5213.05	(Ju) S/ Hy /900	Boden	fond	fondo	base						BEN PEN			12/97
	76.5222.03	S/ Hy /800	Boden	fond	fondo	base							BEN		12/97
	76.5197.06	(Ju) S/T/ Hy /900	Boden	fond	fondo	base			BEN PEN						5/98
	76.5212.06	(Ju) S/T/ Hy /900	Boden	fond	fondo	base				BEN PEN	BEN PEN				5/98
	76.5213.06	(Ju) S/T/ Hy /900	Boden	fond	fondo	base						BEN PEN			5/98
	76.5222.06	S/T/ Hy /900	Boden	fond	fondo	base							BEN		5/98
															5/98

Doc. No.	Index	Issue	DE	FR	IT	GB	Seite/ Page/ Pagina/ Page						
76.9274.50		12/97	Baugruppe	Unité	Unità	Unit	5						
			Verschaltung	revêtement	rivestimento	paneling							

Pos.	Product No.		Bezeichnung	Désignation	Designazione	Designation	BON/BEN/(J)PEN								Intro- duction	
							40	60	80	100	150	200	300	400		
3	76.1180.01	W/800	Blende	bandeau	copertura	filler	BON									12/97
	76.1181.01	W/800	Blende	bandeau	copertura	filler		BON								12/97
	76.1175.01	W/800	Blende	bandeau	copertura	filler			BON	BON						12/97
	76.1182.01	W/800	Blende	bandeau	copertura	filler					BON					12/97
	76.1181.01	W/800	Blende	bandeau	copertura	filler			BEN PEN							12/97
	76.1183.01	W/800	Blende	bandeau	copertura	filler					BEN PEN	BEN PEN				12/97
	76.1184.01	W/800	Blende	bandeau	copertura	filler							BEN PEN			12/97
	76.1185.01	W/800	Blende	bandeau	copertura	filler								BEN		12/97
	76.1180.02	W/900	Blende	bandeau	copertura	filler	BON									12/97
	76.1181.02	W/900	Blende	bandeau	copertura	filler		BON								12/97
	76.1175.02	W/900	Blende	bandeau	copertura	filler			BON	BON						12/97
	76.1182.02	W/900	Blende	bandeau	copertura	filler					BON					12/97
	76.1181.02	W/900	Blende	bandeau	copertura	filler			BEN PEN							12/97
	76.1183.02	W/900	Blende	bandeau	copertura	filler					BEN PEN	BEN PEN				12/97
	76.1184.02	W/900	Blende	bandeau	copertura	filler							BEN PEN			12/97
	76.1185.02	W/900	Blende	bandeau	copertura	filler								BEN		12/97
	76.1180.02	S/N/mR/800	Blende	bandeau	copertura	filler	BON									12/97
	76.1181.02	S/N/mR/800	Blende	bandeau	copertura	filler		BON								12/97
	76.1175.02	S/N/mR/800	Blende	bandeau	copertura	filler			BON	BON						12/97
	76.1182.02	S/N/mR/800	Blende	bandeau	copertura	filler					BON					12/97
	76.1181.02	S/N/mR/800	Blende	bandeau	copertura	filler			BEN PEN							12/97
	76.1183.02	S/N/mR/800	Blende	bandeau	copertura	filler					BEN PEN	BEN PEN				12/97
	76.1184.02	S/N/mR/800	Blende	bandeau	copertura	filler							BEN PEN			12/97
	76.1185.02	S/N/mR/800	Blende	bandeau	copertura	filler								BEN		12/97
	76.1180.04	S/N/mR/900	Blende	bandeau	copertura	filler	BON									12/97
	76.1181.04	S/N/mR/900	Blende	bandeau	copertura	filler		BON								12/97
	76.1175.04	S/N/mR/900	Blende	bandeau	copertura	filler			BON	BON						12/97

Doc. No.	Index	Issue	DE	FR	IT	GB	Seite/ Page/ Pagina/ Page					
76.9274.50		12/97	Baugruppe	Unité	Unità	Unit	6					
			Verschaltung	revêtement	rivestimento	paneling						

Pos.	Product No.		Bezeichnung	Désignation	Designazione	Designation	BON/BEN/(J)PEN								Intro- duction
							40	60	80	100	150	200	300	400	
3	76.1182.04	S/N/mR/900	Blende	bandeau	copertura	filler					BON				12/97
	76.1181.04	S/N/mR/900	Blende	bandeau	copertura	filler			BEN PEN						12/97
	76.1183.04	S/N/mR/900	Blende	bandeau	copertura	filler					BEN PEN	BEN PEN			12/97
	76.1184.04	S/N/mR/900	Blende	bandeau	copertura	filler							BEN PEN		12/97
	76.1185.04	S/N/mR/900	Blende	bandeau	copertura	filler								BEN	12/97
	76.5335.01	S/F/900	Blende	bandeau	copertura	filler	BON								12/97
	76.5335.02	S/F/900	Blende	bandeau	copertura	filler		BON							12/97
	76.5335.03	S/F/900	Blende	bandeau	copertura	filler			BON	BON					12/97
	76.5335.04	S/F/900	Blende	bandeau	copertura	filler					BON				12/97
	76.5335.02	S/F/900	Blende	bandeau	copertura	filler			BEN PEN						12/97
	76.5335.05	S/F/900	Blende	bandeau	copertura	filler					BEN PEN	BEN PEN			12/97
	76.5335.06	S/F/900	Blende	bandeau	copertura	filler							BEN PEN		12/97
	76.5335.07	S/F/900	Blende	bandeau	copertura	filler								BEN	12/97
	76.5376.02	Ju/850-900	Blende	bandeau	copertura	filler				1					12/97
	76.5376.05	Ju/850-900	Blende	bandeau	copertura	filler					1	1			12/97
	76.5376.06	Ju/850-900	Blende	bandeau	copertura	filler							1		12/97
4	76.1147.01	P/700h	Schalterfront	panneau de commande	pannello di comando	switch panel	1	1	1	1	1	1	1	1	12/97
	76.1147.02	C/700h	Schalterfront	panneau de commande	pannello di comando	switch panel	1	1	1	1	1	1	1	1	12/97
	76.1147.03	P/S/700h	Schalterfront	panneau de commande	pannello di comando	switch panel	1	1	1	1	1	1	1	1	12/97
	76.1147.04	C/S/700h	Schalterfront	panneau de commande	pannello di comando	switch panel	1	1	1	1	1	1	1	1	12/97
	76.1202	H/700h	Schalterfront	panneau de commande	pannello di comando	switch panel	1	1	1	1	1	1	1	1	12/97
	76.1148.01	P/800	Schalterfront	panneau de commande	pannello di comando	switch panel	1	1	1	1	1	1	1	1	12/97
	76.1148.02	C/800	Schalterfront	panneau de commande	pannello di comando	switch panel	1	1	1	1	1	1	1	1	12/97
	76.1148.03	P/S/800	Schalterfront	panneau de commande	pannello di comando	switch panel	1	1	1	1	1	1	1	1	12/97
	76.1148.04	C/S/800	Schalterfront	panneau de commande	pannello di comando	switch panel	1	1	1	1	1	1	1	1	12/97
	76.1203	H/800h	Schalterfront	panneau de commande	pannello di comando	switch panel	1	1	1	1	1	1	1	1	12/97

Doc. No.	Index	Issue	DE	FR	IT	GB	Seite/ Page/ Pagina/ Page
76.9274.50		12/97	Baugruppe	Unité	Unità	Unit	7
			Verschaltung	revêtement	rivestimento	paneling	

Pos.	Product No.		Bezeichnung	Désignation	Designazione	Designation	BON/BEN/(J)PEN							Intro- duction	
							40	60	80	100§	150	200	300		400
4	76.5362.01	Ju/P/650h	Schalterfront	panneau de commande	pannello di comando	switch panel			1		1	1	1		12/97
	76.5362.02	Ju/C/650h	Schalterfront	panneau de commande	pannello di comando	switch panel			1		1	1	1		12/97
	76.5362.03	Ju/P/S/650h	Schalterfront	panneau de commande	pannello di comando	switch panel			1		1	1	1		12/97
	76.5362.04	Ju/C/S/650h	Schalterfront	panneau de commande	pannello di comando	switch panel			1		1	1	1		12/97
	76.5288.01	Ju/P/700h	Schalterfront	panneau de commande	pannello di comando	switch panel			1		1	1	1		12/97
	76.5288.02	Ju/C/700h	Schalterfront	panneau de commande	pannello di comando	switch panel			1		1	1	1		12/97
	76.5288.03	Ju/P/S/700h	Schalterfront	panneau de commande	pannello di comando	switch panel			1		1	1	1		12/97
	76.5288.04	Ju/C/S/700h	Schalterfront	panneau de commande	pannello di comando	switch panel			1		1	1	1		12/97
	76.5360.01	Ju/P/750h	Schalterfront	panneau de commande	pannello di comando	switch panel			1		1	1	1		12/97
	76.5360.02	Ju/C/750h	Schalterfront	panneau de commande	pannello di comando	switch panel			1		1	1	1		12/97
	76.5360.03	Ju/P/S/750h	Schalterfront	panneau de commande	pannello di comando	switch panel			1		1	1	1		12/97
	76.5360.04	Ju/C/S/750h	Schalterfront	panneau de commande	pannello di comando	switch panel			1		1	1	1		12/97
5	76.1172	RW/700h	Schalterfront	panneau de commande	pannello di comando	switch panel	1	1	1	1	1				12/97
	76.1173	RW/800h	Schalterfront	panneau de commande	pannello di comando	switch panel	1	1	1	1	1				12/97
6	76.5162.02	700h	Frontblech	tôle frontale	lamiera frontale	front panel	BON								12/97
	76.5163.02	700h	Frontblech	tôle frontale	lamiera frontale	front panel		BON							12/97
	76.5164.02	700h	Frontblech	tôle frontale	lamiera frontale	front panel			BON						12/97
	76.5164.04	700h/800	Frontblech	tôle frontale	lamiera frontale	front panel				BON					12/97
	76.5164.06	700h	Frontblech	tôle frontale	lamiera frontale	front panel				BON					12/97
	76.5165.02	700h	Frontblech	tôle frontale	lamiera frontale	front panel					BON				12/97
	76.5283.02	700h/RW	Frontblech	tôle frontale	lamiera frontale	front panel	BON								12/97
	76.5282.02	700h/RW	Frontblech	tôle frontale	lamiera frontale	front panel		BON							12/97
	76.5281.02	700h/RW	Frontblech	tôle frontale	lamiera frontale	front panel			BON						12/97
	76.5281.04	700h/800/RW	Frontblech	tôle frontale	lamiera frontale	front panel				BON					12/97
	76.5281.06	700h/RW	Frontblech	tôle frontale	lamiera frontale	front panel				BON					12/97
	76.5284.02	700h/RW	Frontblech	tôle frontale	lamiera frontale	front panel					BON				12/97
	76.5082.01	700h	Frontblech	tôle frontale	lamiera frontale	front panel			BEN PEN						12/97
	76.5082.02	700h	Frontblech	tôle frontale	lamiera frontale	front panel			BEN PEN						12/97
	76.5722.02	W/700h	Frontblech	tôle frontale	lamiera frontale	front panel			BEN -S						40. week 09/04
	76.5647.02	700h	Frontblech	tôle frontale	lamiera frontale	front panel			BEN PEN						06/03
	76.5171.04	700h	Frontblech	tôle frontale	lamiera frontale	front panel				BEN					12/97

Doc. No.	Index	Issue	DE	FR	IT	GB	Seite/ Page/ Pagina/ Page						
76.9274.50		12/97	Baugruppe	Unité	Unità	Unit	7						
			Verschalung	revêtement	rivestimento	paneling							

6	76.5723.04	W/700h	Frontblech	tôle frontale	lamiera frontale	front panel						BEN-S				40. week 09/04
	76.5648.04	700h	Frontblech	tôle frontale	lamiera frontale	front panel						BEN PEN				06/03
	76.5171.02	700h	Frontblech	tôle frontale	lamiera frontale	front panel						BEN PEN				12/97
	76.5723.02	W/700h	Frontblech	tôle frontale	lamiera frontale	front panel						BEN-S				40. week 09/04
	76.5648.02	700h	Frontblech	tôle frontale	lamiera frontale	front panel						BEN PEN				06/03
	76.5137.02	700h	Frontblech	tôle frontale	lamiera frontale	front panel							BEN PEN			12/97
	76.5724.02	W/700h	Frontblech	tôle frontale	lamiera frontale	front panel							BEN-S			40. week 09/04
	76.5649.02	700h	Frontblech	tôle frontale	lamiera frontale	front panel							BEN PEN			06/03
	76.5299.02	700h	Frontblech	tôle frontale	lamiera frontale	front panel								BEN		12/97
	76.5725.02	W/700h	Frontblech	tôle frontale	lamiera frontale	front panel								BEN-S		40. week 09/04
	76.5650.02	700h	Frontblech	tôle frontale	lamiera frontale	front panel								BEN		06/03
	76.5162.01	800h	Frontblech	tôle frontale	lamiera frontale	front panel	BON									12/97
	76.5163.01	800h	Frontblech	tôle frontale	lamiera frontale	front panel		BON								12/97
	76.5164.01	800h	Frontblech	tôle frontale	lamiera frontale	front panel			BON							12/97
	76.5164.03	800h/800	Frontblech	tôle frontale	lamiera frontale	front panel				BON						12/97
	76.5164.05	800h	Frontblech	tôle frontale	lamiera frontale	front panel				BON						12/97
	76.5165.01	800h	Frontblech	tôle frontale	lamiera frontale	front panel					BON					12/97
	76.5283.01	800h/RW	Frontblech	tôle frontale	lamiera frontale	front panel	BON									12/97
	76.5282.01	800h/RW	Frontblech	tôle frontale	lamiera frontale	front panel		BON								12/97
	76.5281.01	800h/RW	Frontblech	tôle frontale	lamiera frontale	front panel			BON							12/97
	76.5281.03	800h/800/RW	Frontblech	tôle frontale	lamiera frontale	front panel				BON						12/97
	76.5281.05	800h/RW	Frontblech	tôle frontale	lamiera frontale	front panel				BON						12/97
	76.5284.01	800h/RW	Frontblech	tôle frontale	lamiera frontale	front panel					BON					12/97
	76.5082.01	800h	Frontblech	tôle frontale	lamiera frontale	front panel					BEN PEN					12/97
	76.5722.01	S/800h	Frontblech	tôle frontale	lamiera frontale	front panel					BEN -S					40. week 09/04
	76.5647.01	800h	Frontblech	tôle frontale	lamiera frontale	front panel					BEN PEN					06/03
	76.5171.01	700h	Frontblech	tôle frontale	lamiera frontale	front panel						BEN PEN				12/97

Doc. No.	Index	Issue	DE	FR	IT	GB	Seite/ Page/ Pagina/ Page			
76.9274.50		12/97	Baugruppe	Unité	Unità	Unit	8			
			Verschaltung	revêtement	rivestimento	paneling				

Pos.	Product No.		Bezeichnung	Désignation	Designazione	Designation	BON/BEN/(J)PEN							Intro- duction	
							40	60	80	100	150	200	300		400
6	76.5723.01	S/700h	Frontblech	tôle frontale	lamiera frontale	front panel						BEN-S			40. week 09/04
	76.5171.03	800h	Frontblech	tôle frontale	lamiera frontale	front panel					BEN PEN				12/97
	76.5723.03	S/700h	Frontblech	tôle frontale	lamiera frontale	front panel					BEN-S				40. week 09/04
	76.5648.03	800h	Frontblech	tôle frontale	lamiera frontale	front panel					BEN PEN				06/03
	76.5648.01	800h	Frontblech	tôle frontale	lamiera frontale	front panel					BEN PEN				06/03
	76.5137.01	800h	Frontblech	tôle frontale	lamiera frontale	front panel						BEN PEN			12/97
	76.5724.01	S/700h	Frontblech	tôle frontale	lamiera frontale	front panel						BEN-S			40. week 09/04
	76.5649.01	800h	Frontblech	tôle frontale	lamiera frontale	front panel						BEN PEN			06/03
	76.5299.01	800h	Frontblech	tôle frontale	lamiera frontale	front panel							BEN		12/97
	76.5725.01	S/700h	Frontblech	tôle frontale	lamiera frontale	front panel							BEN-S		40. week 09/04
	76.5650.01	800h	Frontblech	tôle frontale	lamiera frontale	front panel							BEN		06/03
	76.5356.01	Ju/650h	Frontblech	tôle frontale	lamiera frontale	front panel			1						12/97
	76.5289.01	Ju/650h	Frontblech	tôle frontale	lamiera frontale	front panel					1				12/97
	76.5289.03	Ju/650h	Frontblech	tôle frontale	lamiera frontale	front panel						1			12/97
	76.5357.01	Ju/650h	Frontblech	tôle frontale	lamiera frontale	front panel							1		12/97
	76.5356.02	Ju/750h	Frontblech	tôle frontale	lamiera frontale	front panel			1						12/97
	76.5289.02	Ju/750h	Frontblech	tôle frontale	lamiera frontale	front panel					1				12/97
	76.5289.04	Ju/750h	Frontblech	tôle frontale	lamiera frontale	front panel						1			12/97
	76.5357.02	Ju/750h	Frontblech	tôle frontale	lamiera frontale	front panel							1		12/97

Doc. No.	Index	Issue	DE	FR	IT	GB	Seite/ Page/ Pagina/ Page						
76.9274.50		12/97	Baugruppe	Unité	Unità	Unit	9						
			Verschalung	revêtement	rivestimento	paneling							

Pos.	Product No.		Bezeichnung	Désignation	Designazione	Designation	BON/BEN/(J)PEN								Intro- duction
							40	60	80	100	150	200	300	400	
7	76.5223.01	F/700h	Rückwand	paroi arrière	parete posteriore	rear panel	BON								12/97
	76.5224.01	F/700h	Rückwand	paroi arrière	parete posteriore	rear panel		BON							12/97
	76.5225.01	F/700h	Rückwand	paroi arrière	parete posteriore	rear panel			BON	BON					12/97
	76.5226.01	F/700h	Rückwand	paroi arrière	parete posteriore	rear panel					BON				12/97
	76.5224.01	F/700h	Rückwand	paroi arrière	parete posteriore	rear panel			BEN PEN						12/97
	76.5227.01	F/700h	Rückwand	paroi arrière	parete posteriore	rear panel					BEN PEN	BEN PEN			12/97
	76.5138.01	F/700h	Rückwand	paroi arrière	parete posteriore	rear panel							BEN PEN		12/97
	76.5228.01	F/700h	Rückwand	paroi arrière	parete posteriore	rear panel								BEN	12/97
	76.5223.02	F/800h	Rückwand	paroi arrière	parete posteriore	rear panel	BON								12/97
	76.5224.02	F/800h	Rückwand	paroi arrière	parete posteriore	rear panel		BON							12/97
	76.5225.02	F/800h	Rückwand	paroi arrière	parete posteriore	rear panel			BON	BON					12/97
	76.5226.02	F/800h	Rückwand	paroi arrière	parete posteriore	rear panel					BON				12/97
	76.5224.02	F/800h	Rückwand	paroi arrière	parete posteriore	rear panel			BEN PEN						12/97
	76.5227.02	F/800h	Rückwand	paroi arrière	parete posteriore	rear panel					BEN PEN	BEN PEN			12/97
	76.5138.02	F/800h	Rückwand	paroi arrière	parete posteriore	rear panel							BEN PEN		12/97
	76.5228.02	F/800h	Rückwand	paroi arrière	parete posteriore	rear panel								BEN	12/97
7	76.1174.01	N/B/700h/L	Rückwand	paroi arrière	parete posteriore	rear panel	BON								12/97
	76.1189.01	N/B/700h/R	Rückwand	paroi arrière	parete posteriore	rear panel	BON								12/97
	76.1174.02	N/B/700h/L	Rückwand	paroi arrière	parete posteriore	rear panel		BON							12/97
	76.1189.02	N/B/700h/R	Rückwand	paroi arrière	parete posteriore	rear panel		BON							12/97
	76.1174.03	N/B/700h/L	Rückwand	paroi arrière	parete posteriore	rear panel			BON	BON					12/97
	76.1189.03	N/B/700h/R	Rückwand	paroi arrière	parete posteriore	rear panel			BON	BON					12/97
	76.1174.04	N/B/700h/L	Rückwand	paroi arrière	parete posteriore	rear panel					BON				12/97
	76.1189.04	N/B/700h/R	Rückwand	paroi arrière	parete posteriore	rear panel					BON				12/97
	76.1174.02	N/B/700h/L	Rückwand	paroi arrière	parete posteriore	rear panel			BEN PEN						12/97
	76.1189.02	N/B/700h/R	Rückwand	paroi arrière	parete posteriore	rear panel			BEN PEN						12/97

Doc. No.	Index	Issue	DE	FR	IT	GB	Seite/ Page/ Pagina/ Page					
76.9274.50		12/97	Baugruppe	Unité	Unità	Unit	10					
			Verschalung	revêtement	rivestimento	paneling						

Pos.	Product No.		Bezeichnung	Désignation	Designazione	Designation	BON/BEN/(J)PEN								Introduction
							40	60	80	100	150	200	300	400	
7	76.1174.05	N/B/700h/L	Rückwand	paroi arrière	parete posteriore	rear panel					BEN PEN	BEN PEN			12/97
	76.1189.05	N/B/700h/R	Rückwand	paroi arrière	parete posteriore	rear panel					BEN PEN	BEN PEN			12/97
	76.1174.06	N/B/700h/L	Rückwand	paroi arrière	parete posteriore	rear panel							BEN PEN		12/97
	76.1189.06	N/B/700h/R	Rückwand	paroi arrière	parete posteriore	rear panel							BEN PEN		12/97
	76.1174.07	N/B/700h/L	Rückwand	paroi arrière	parete posteriore	rear panel								BEN	12/97
	76.1189.07	N/B/700h/R	Rückwand	paroi arrière	parete posteriore	rear panel								BEN	12/97
7	76.1174.11	N/B/700h/L	Rückwand	paroi arrière	parete posteriore	rear panel	BON								12/97
	76.1189.11	N/B/700h/R	Rückwand	paroi arrière	parete posteriore	rear panel	BON								12/97
	76.1174.12	N/B/700h/L	Rückwand	paroi arrière	parete posteriore	rear panel		BON							12/97
	76.1189.12	N/B/700h/R	Rückwand	paroi arrière	parete posteriore	rear panel		BON							12/97
	76.1174.13	N/B/700h/L	Rückwand	paroi arrière	parete posteriore	rear panel			BON	BON					12/97
	76.1189.13	N/B/700h/R	Rückwand	paroi arrière	parete posteriore	rear panel			BON	BON					12/97
	76.1174.14	N/B/700h/L	Rückwand	paroi arrière	parete posteriore	rear panel					BON				12/97
	76.1189.14	N/B/700h/R	Rückwand	paroi arrière	parete posteriore	rear panel					BON				12/97
	76.1174.12	N/B/700h/L	Rückwand	paroi arrière	parete posteriore	rear panel			BEN PEN						12/97
	76.1189.12	N/B/700h/R	Rückwand	paroi arrière	parete posteriore	rear panel			BEN PEN						12/97
	76.1174.15	N/B/700h/L	Rückwand	paroi arrière	parete posteriore	rear panel					BEN PEN	BEN PEN			12/97
	76.1189.15	N/B/700h/R	Rückwand	paroi arrière	parete posteriore	rear panel					BEN PEN	BEN PEN			12/97
	76.1174.16	N/B/700h/L	Rückwand	paroi arrière	parete posteriore	rear panel							BEN PEN		12/97
	76.1189.16	N/B/700h/R	Rückwand	paroi arrière	parete posteriore	rear panel							BEN PEN		12/97
	76.1174.17	N/B/700h/L	Rückwand	paroi arrière	parete posteriore	rear panel								BEN	12/97
	76.1189.17	N/B/700h/R	Rückwand	paroi arrière	parete posteriore	rear panel								BEN	12/97

Doc. No.	Index	Issue	DE	FR	IT	GB	Seite/ Page/ Pagina/ Page					
76.9274.50		12/99	Baugruppe	Unité	Unità	Unit	11					
			Verschalung	revêtement	rivestimento	paneling						

Pos.	Product No.		Bezeichnung	Désignation	Designazione	Designation	BON/BEN/PEN								Intro- duction	
							40	60	80	100	150	200	300	400		
7	76.5229.01	N/E/700h	Rückwand	paroi arrière	parete posteriore	rear panel	BON									12/99
	76.5229.02	N/E/800h	Rückwand	paroi arrière	parete posteriore	rear panel	BON									12/99
	76.5230.01	N/E/700h	Rückwand	paroi arrière	parete posteriore	rear panel		BON	BEN PEN							12/99
	76.5230.02	N/E/800h	Rückwand	paroi arrière	parete posteriore	rear panel		BON	BEN PEN							12/99
	76.5231.01	N/E/700h	Rückwand	paroi arrière	parete posteriore	rear panel			BON	BON						12/99
	76.5231.02	N/E/800h	Rückwand	paroi arrière	parete posteriore	rear panel			BON	BON						12/99
	76.5232.01	N/E/700h	Rückwand	paroi arrière	parete posteriore	rear panel					BON					12/99
	76.5232.02	N/E/800h	Rückwand	paroi arrière	parete posteriore	rear panel					BON					12/99
	76.5233.01	N/E/700h	Rückwand	paroi arrière	parete posteriore	rear panel					BEN PEN	BEN PEN				12/99
	76.5233.02	N/E/800h	Rückwand	paroi arrière	parete posteriore	rear panel					BEN PEN	BEN PEN				12/99
	76.5234.01	N/E/700h	Rückwand	paroi arrière	parete posteriore	rear panel							BEN PEN			12/99
	76.5234.02	N/E/800h	Rückwand	paroi arrière	parete posteriore	rear panel							BEN PEN			12/99
	76.5235.01	N/E/700h	Rückwand	paroi arrière	parete posteriore	rear panel								BEN PEN		12/99
	76.5235.02	N/E/800h	Rückwand	paroi arrière	parete posteriore	rear panel								BEN PEN		12/99

Doc. No.	Index	Issue	DE	FR	IT	GB	Seite/ Page/ Pagina/ Page
76.9274.50		12/97	Baugruppe	Unité	Unità	Unit	12
			Verschalung	revêtement	rivestimento	paneling	

	Erklärung	explication	spiegazione	explanation
W	Wandbefestigung	montage mural	montaggio a muro	wall mounted
S	Standmontage	montage au sol	montaggio a pavimento	floor mounting
F	freistehend	isolé	isolato	free standing
N	an Wand	contre cloison	contro la parete	against wall
T	mit Füßen	avec pieds	con piede	with feet
A	alle Aufstellungsarten	toutes variantes	tutte varinti	all variants
Hy	Hygienemodell	modèle hygiénique	modello igienico	hygienic model
mR	mit Rückwand	avec paroi arrière	con parete posteriore	with rear panel
B	Anschluss vom Boden	raccordement au sol	raccordo dal pavimento	connection from bottom
E	Anschluss von Wand	raccordement au cloison	raccordo dalla parete	connection from wall
800-900	Gerätetiefe	profondeur d'appareil	profondità dell'apparecchio	appliance depth
650h-800h	Gerätehöhe	hauteur d'appareil	altezza dell'apparecchio	appliance height
L	links	gauche	sinistra	left
R	rechts	droit	destra	right
Ju	Ausführung Juno	modèle Juno	modello Juno	model Juno
RW	Rührwerk	melangeur	mescolatore	stirring system
2G	2 Geräte zusammen	2 appareils ensemble	2 apparecchi insieme	2 appl. together
oW	ohne Seitenwand	sans paroi latérale	senza parete laterale	without side panel
P	Steuerung	commande	comando	control system
C	Prozess Comfort			
H	Comfort			
H	Handsteuerung	commande manuelle	regolazione a mano	manual control
S	Hauptschalter	interrupteur principal	interruttore generale	main interruptor

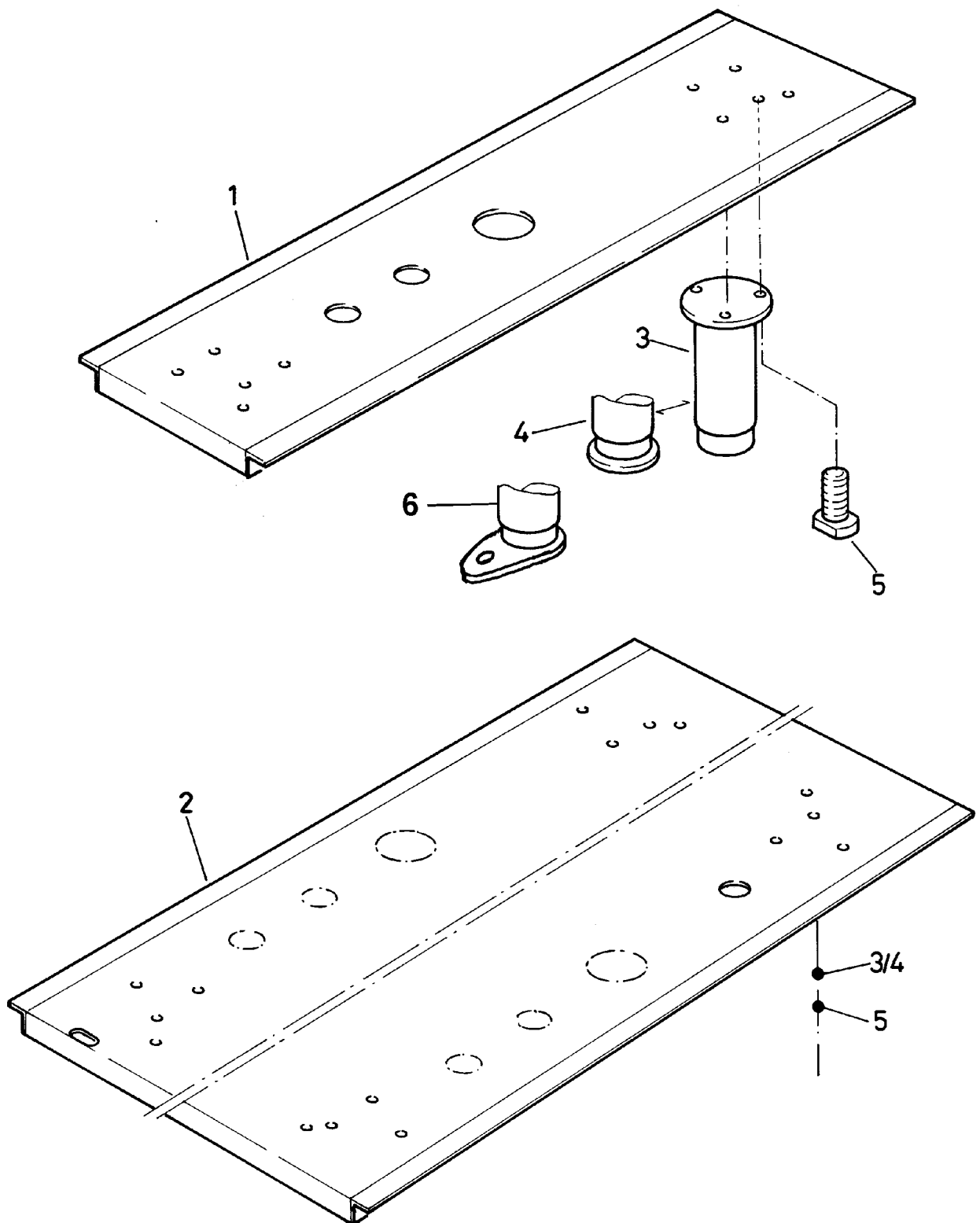

Doc. No.	Index	Issue	DE	FR	IT	GB	Seite/ Page/ Pagina/ Page
76.9274.51		06/98	Baugruppe	Unité	Unità	Unit	1
			Füsse	pieds	piede	feet	

Pos.	Product No.	Bezeichnung	Désignation	Designatione	Designation	BEN/PEN		Introduction
1	76.5197.06	Bodenplatte	plaque de fond	placca del suolo	base plate	BEN/PEN-080		06/98
	76.5212.06	Bodenplatte	plaque de fond	placca del suolo	base plate	BEN/PEN-150/200		06/98
	76.5213.06	Bodenplatte	plaque de fond	placca del suolo	base plate	BEN/PEN-300		06/98
	76.5222.06	Bodenplatte	plaque de fond	placca del suolo	base plate	BEN-400		06/98
3	72.4344	Fuss	ped	piede	foot		100mm	06/98
	72.4249	Fuss	ped	piede	foot		200mm	06/98
4	72.4351	Fuss	ped	piede	foot	Marine	100mm	06/98
	72.4250	Fuss	ped	piede	foot	Marine	200mm	06/98
5	75.5006.06	Schraube	vis	vite	screw		M4	06/98
6	72.4351.02	Fuss	ped	piede	foot	Marine	100mm	04/00
		Fuss	ped	piede	foot	Marine	200mm	04/00

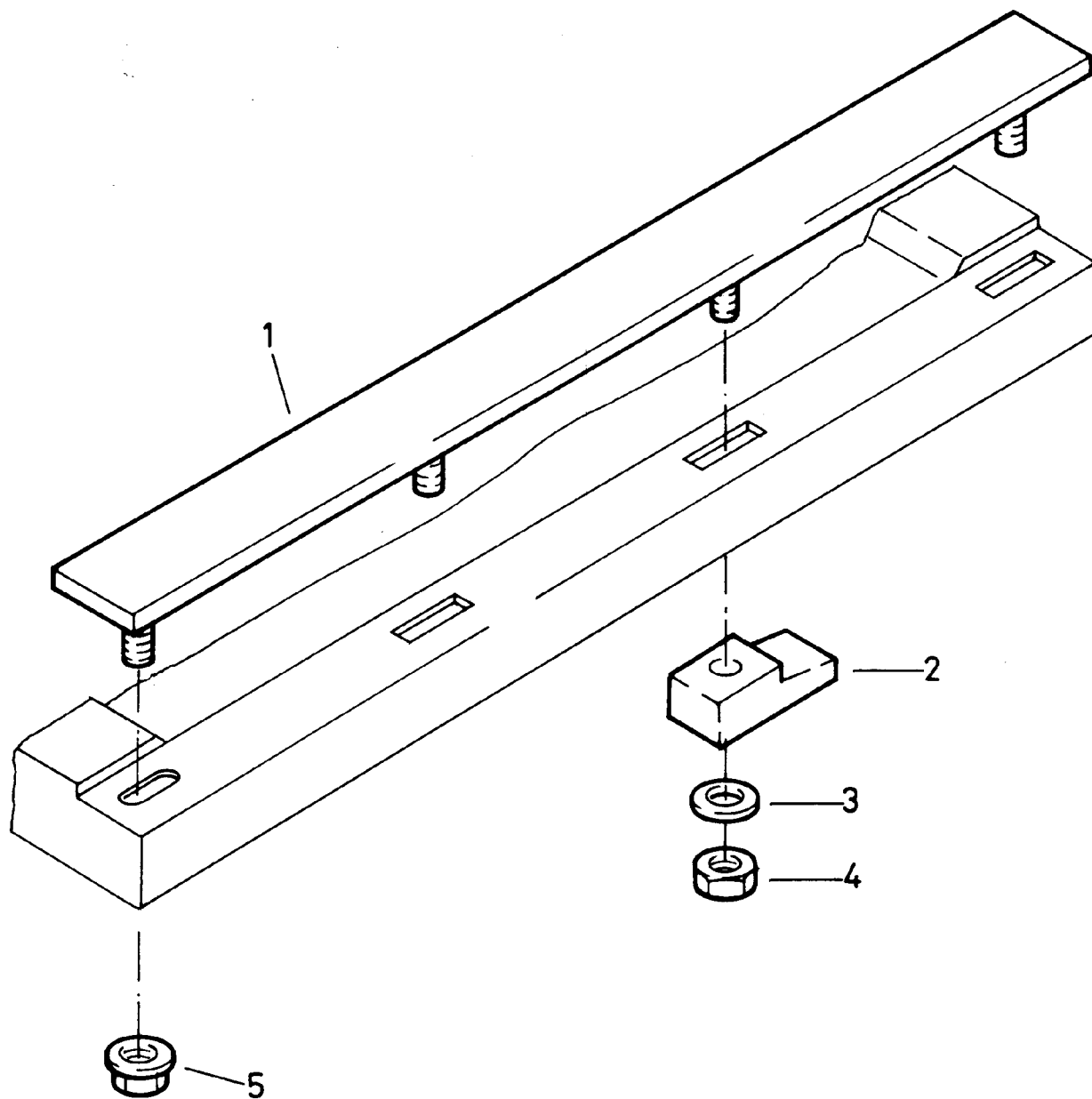

Doc. No.	Index	Issue	DE	FR	IT	GB	Seite/ Page/ Pagina/ Page		
76.9274.52	1	09.97	Baugruppe	Unité	Unità	Unit	1		
			Verbindungs- schiene	rail intermédiaire	asta coniungimento	intermediate rail			

Pos.	Product No.	Service No.	Bezeichnung	Désignation	Designazione	Designation	Type			Introduction
1-5	76.2227		Endschiene	rail terminal	asta finale	end rail	800	1		10/00
	76.2229		Endschiene	rail terminal	asta finale	end rail	900	1		10/00
	71.0575		Endschiene	rail terminal	asta finale	end rail	1000	1		06/82
	76.2228		Zwischenschiene	rail d'assemblage	asta di congiungimento	intermediate rail	800	1		10/00
	76.2230		Zwischenschiene	rail d'assemblage	asta di congiungimento	intermediate rail	900	1		10/00
	76.2142.01		Zwischenschiene mit Ausschnitt Länge rechts 1000 Länge links 900	rail d'assemblage avec découpe longueur droit 1000 longueur gauche 900	asta di congiungimento con foro lunghezza destra 1000 lunghezza sinistra 900	intermediate rail with cutout length right 1000 length left 900	1000	1		08.98
	76.2142.02		Zwischenschiene mit Ausschnitt Länge rechts 900 Länge links 1000	rail d'assemblage avec découpe longueur droit 900 longueur gauche 1000	asta di congiungimento con foro lunghezza destra 900 lunghezza sinistra 1000	intermediate rail with cutout length right 900 length left 1000	1000	1		08.98
	76.2143.01		Zwischenschiene ohne Ausschnitt Gerät: Länge rechts 1000 Länge links 900	rail d'assemblage sans découpe appareil: longueur droit 1000 longueur gauche 900	asta di congiungimento senza foro apparecchio: lunghezza destra 1000 lunghezza sinistra 900	intermediate rail without cutout appliance: length right 1000 length left 900	1000	1		08.98
	76.2143.02		Zwischenschiene ohne Ausschnitt Gerät: Länge rechts 900 Länge links 1000	rail d'assemblage sans découpe appareil: longueur droit 900 longueur gauche 1000	asta di congiungimento senza foro apparecchio: lunghezza destra 900 lunghezza sinistra 1000	intermediate rail without cutout appliance: length right 900 length left 1000	1000	1		08.98
2	705 040 074		Keil	clavette	cuneo	wedge		3/6		06/82
3	1701 5047		Federring	anneau de ressort	anello di molla	spring ring	M6	3/6		06/82
4	1701 3016	1101 8572	Mutter	écrou	dado	nut	M6/0.8d	3/6		06/82
5	712 044 120.06	1101 8577	Mutter	écrou	dado	nut	M6	3/6		06/82

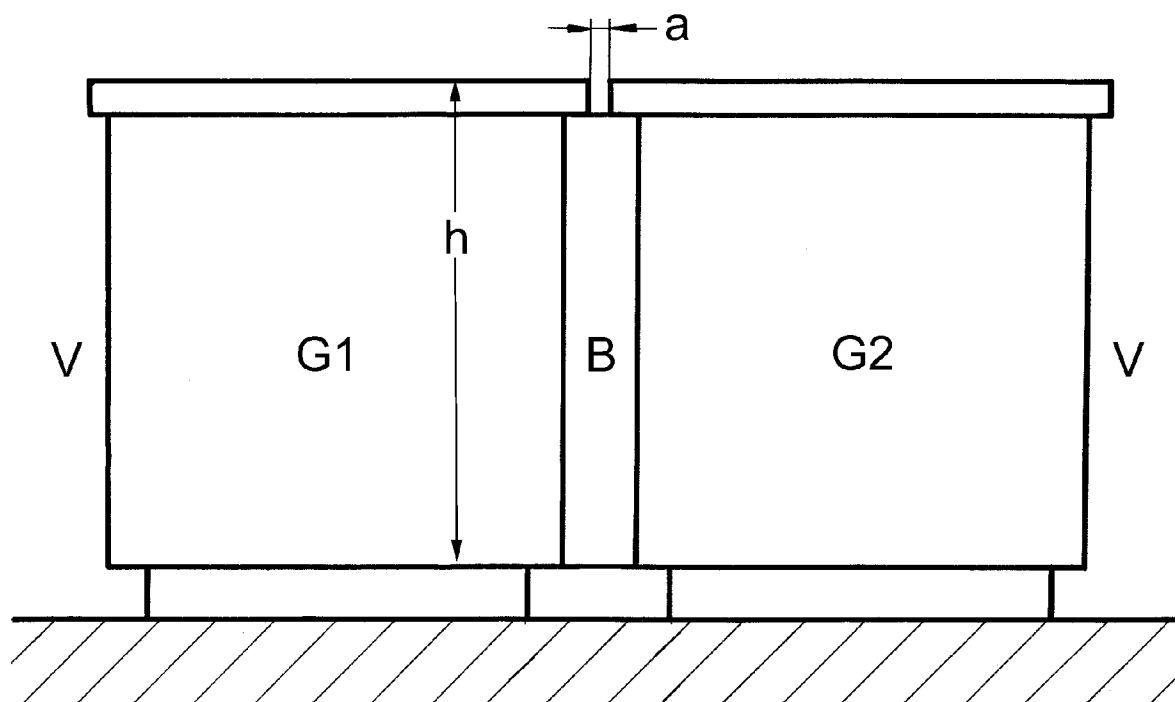

	Erklärung	explication	spiegazione	explanation
B	Blende	bandeau	copertura	filler
G1	Gerät auf linker Seite	appareil à côté gauche	apparecchio a sinistra	appliance on the left
G2	Gerät auf rechter Seite	appareil à côté droite	apparecchio a destra	appliance on the right
V	Vorderseite	avant	parte frontale	front
h	Gerätehöhe mm	hauteur d'appareil mm	altezza dell'apparecchio mm	appliance height mm
a	Abstand mm	distance mm	distanza mm	distance mm
SK	Standkochkessel	marmite fixe	pentola	stationary boiling pan
KA	Kippapparat	appareil basculant	apparecchio ribaltabile	tilting appliance
HE	Herd	fourneau	cucina	range
ZT	Zwischentisch	table intermédiaire	tavolo intermedio	centre-spreader

DE	FR	IT	GB	76.9274.60 01/99
Baugruppe	Unité	Unità	Unit	Seite/page/pagina/page
Blende B Geräte Rücken an Rücken	Bandeau B Appareils dos à dos	Copertura B Apparechi schiena a schiena	Filler B Appliances back to back	1

G1	G2	h	a	B
KA	KA	800	0	76.1128.03
KA	SK	800	0	76.1299.01
KA	HE	800	0	76.1300.01
HE	KA	800	0	76.1301.01
KA	ZT	800	0	76.1128.02
ZT	KA	800	0	76.1128.02
SK	SK	800	0	76.5425.01
SK	KA	800	0	76.1299.01
SK	HE	800	0	76.5426.01
HE	SK	800	0	76.5426.01
SK	ZT	800	0	76.5426.05
ZT	SK	800	0	76.5426.05
KA	KA	800	10	76.1128.07
KA	SK	800	10	76.1299.02
KA	HE	800	10	76.1300.02
HE	KA	800	10	76.1301.02
KA	ZT	800	10	76.1128.09
ZT	KA	800	10	76.1128.09
SK	SK	800	10	76.5425.02
SK	KA	800	10	76.1299.02
SK	HE	800	10	76.5426.02
HE	SK	800	10	76.5426.02
SK	ZT	800	10	76.5426.06
ZT	SK	800	10	76.5426.06
KA	KA	700	0	76.1128.06
KA	SK	700	0	76.1299.03
KA	HE	700	0	76.1300.03
HE	KA	700	0	76.1301.03
KA	ZT	700	0	76.1128.05
ZT	KA	700	0	76.1128.05
SK	SK	700	0	76.5425.03
SK	KA	700	0	76.1299.03
SK	HE	700	0	76.5426.03
HE	SK	700	0	76.5426.03
SK	ZT	700	0	76.5426.07
ZT	SK	700	0	76.5426.07
KA	KA	700	10	76.1128.08
KA	SK	700	10	76.1299.04
KA	HE	700	10	76.1300.04
HE	KA	700	10	76.1301.04
KA	ZT	700	10	76.1128.10
ZT	KA	700	10	76.1128.10
SK	SK	700	10	76.5425.04
SK	KA	700	10	76.1299.04
SK	HE	700	10	76.5426.04
HE	SK	700	10	76.5426.04
SK	ZT	700	10	76.5426.08
ZT	SK	700	10	76.5426.08

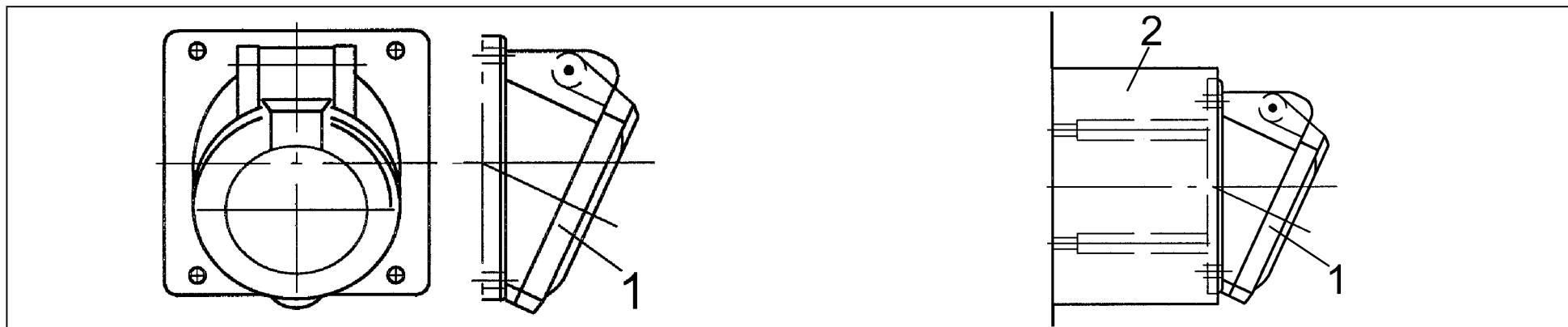

Doc. No.	Issue	DE	FR	IT	GB	Seite/ Page/ Pagina/ Page
76.9274.65	07/00	Baugruppe Steckdose	Unité prise	Unità presa di corrente	Unit socket	1

Pos.	Product No.	Service No.	Bezeichnung	Désignation	Designazione	Designation	Type	Introduction
1	1115 1443		Steckdose EURO	prise EURO	presa di corrente EURO	socket EURO	16A/3N/400V	07/00
	1115 1444		Steckdose EURO	prise EURO	presa di corrente EURO	socket EURO	32A/3N/400V	07/00
	1115 1579		Steckdose CH	prise CH	presa di corrente CH	socket CH	16A/1N/230V	07/00
	1115 1578		Steckdose CH	prise CH	presa di corrente CH	socket CH	16A/3N/400V	07/00
2	1115 1445		Gehäuse EURO	boîtier EURO	base EURO	housing EURO		07/00

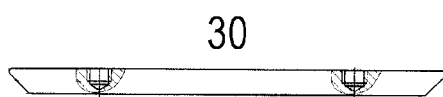
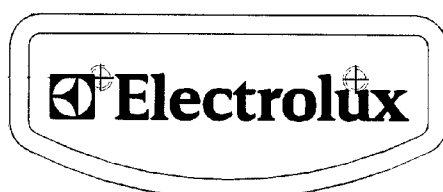
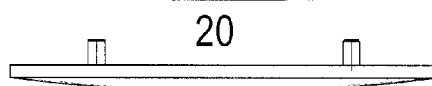
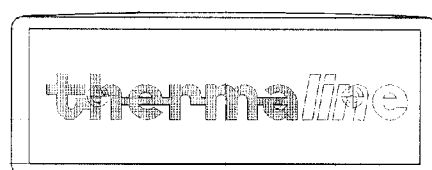
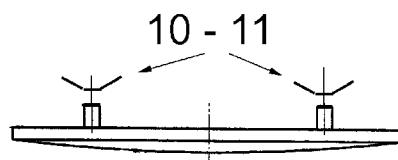
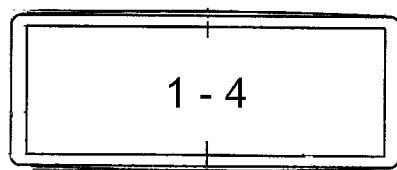

Pos.	Produkt Nr.	Service Nr.	Bezeichnung	désignation	designazione	designation	
			Baugruppe Schild	unité plaquette	unità placchetta	unit label	76.9274.100 1 10.00
1	72.2252		THERMA				1
2	72.6384		THERMALINE				1
3	76.3177		JUNOLINE				1
4	1201 2031		ELECTROLUX				1
10	1701 5072		Haltering	anneau de fixation	anello di sostegno	retaining ring	Pos. 1÷3 2
11	1201 2032		Haltering	anneau de fixation	anello di sostegno	retaining ring	Pos. 4 2
20	72.6384		THERMALINE				1
30	1201 2060		ELECTROLUX				1

**Ersatzteillisten
Listes des pièces de rechange
Liste dei pezzi di ricambio
Spare parts lists**

**DRUCKKOCHKESSEL
MARMITES À PRESSION
PENTOLE A PRESSIONE
PRESSURE BOILING PANS**

**STRATOS
JPEN**

D, F, I, GB

76.9274 (10)